



**SERIES 2 LOADER
PW220 & PT220
Operator's Manual**



We thank you for choosing the Kanga Loader.

Your machine is the result of extensive design and development and is acknowledged as being the superior product in its category. We congratulate you on your discerning choice and wish you many years of productive service!

Read this manual carefully before operating your machine. It contains important technical information, safety precautions, and operating instructions. With correct operation and attention to maintenance procedures, you are ensured of a long, safe, and trouble-free working life for your Kanga Loader.

We advise you to study and understand this manual before undertaking any maintenance. Keep it with your machine at all times as a ready reference. Some illustrations in this publication show details or attachments that may be different from those of your machine. In addition, continuing improvements and advancement in product design may have resulted in changes to your machine that are not present in this publication. If you have any questions, please do not hesitate to contact us.

Safety first!

Safety guidelines and warnings are highlighted throughout this manual. These address potential hazards that may arise during the typical daily operation and maintenance of your loader. You must know and observe these safety guidelines and ensure that all personnel working on or near your loader understand and practice them as well.



Proprietary Statement

© Copyright 2023 Kanga Loaders (Kanga) - fully owned subsidiary of Digga Australia Pty Ltd. All rights reserved. No part of this publication may be reproduced, photocopied, stored on a retrieval system, or transmitted without the express prior written consent of the publisher.

Disclaimer

While all care has been taken in the development of this product, Kanga makes no representation or warranty that this document is accurate, error-free, or up to date and no loss of any kind is accepted by Kanga or its agents arising from the use of this document.

Kanga makes no representations or warranties with respect to the contents of this document, and specifically disclaims any express or implied warranties or fitness for any particular purpose. Furthermore, Kanga reserves the right to revise this publication and to make changes to its contents, at any time, without obligation to notify any person or entity of such revisions or changes.

Trade marks

Kanga owns ® registered trade marks in Australia, the United States of America and other countries including the Kangaroo logo (AU - 529784), "KANGA" (AU - 1178397), the Kanga Loaders logo (AU - 529784). "BUSINESS ON A TRAILER" (AU - 1172336), "KANGA KID" (AU - 855550).

This document includes use of trade marks that are the property of Kanga, including registered trade marks and trade marks that are the subject of pending applications, or which are otherwise protected by law. You may not use or infringe these trade marks or the names "Digga", "Kanga Loaders", or the name of any of our related companies, without the express written consent of Kanga.

Copyright

This document, its contents, the material, and content (including, but not limited to, artistic and literary works) on the Kanga Loaders website are owned or licensed by Kanga and protected by copyright under the laws of the Australia, United States of America and other countries.

You may view this document for the purposes of use and operation of the Kanga product purchased in connection with the issue of this document.

You may view the contents of our website and save an electronic copy of the website solely for the usual operation of your web browser visiting the site.

You must not otherwise reproduce, transmit (including broadcast), adapt, distribute, sell, modify or publish or otherwise use any of the material on this document or our website, including audio and video excerpts, except as permitted by statute or with Kanga's prior written consent.

Patent and design rights

The products, inventions and processes subject of this document may be protected by granted patents or registered designs owned or licensed by Kanga. You must not use or exploit such products, inventions and/or processes in a manner that would constitute infringement of Kanga's or its licensors' rights in such patents or registered designs without the express written consent of Kanga, or otherwise as expressly permitted under this document.

Framing

You must not frame any of the material appearing on this document or on Kanga websites and marketing material except in accordance with the Digga Linking and Framing Policy (contained at <https://www.kangaloaderusa.com/terms/>) or otherwise in accordance with Kanga's prior written consent.



Table of Contents

- Identify Your Kanga Loader7**
 - Read Your Product Plate7
 - Understand the Model Number7

- Safety Information8**
 - Understand Safety Warnings and Symbols.....8
 - Safety Decal Labels9
 - Safe Work Practices—Pictograms12
 - General Safety Rules13

- Practice Safety at All Times13**
 - Working on Slopes.....14
 - Tipping Load and Rated Operating Capacity (ROC)16
 - Before You Dig.....18
 - Personal Protective Equipment (PPE)19

- Complete a Risk Assessment20**
 - Five Steps to an Effective Risk Assessment20
 - Risk Assessment Matrix21
 - Be Work-Ready22

- Operate Your Kanga Loader23**
 - Inspection After Delivery.....23
 - Check Before Using.....23
 - Loading and Unloading24
 - Unloading24
 - Loading25
 - Lashing Points25
 - Safety in the Work Zone25
 - Lashing Plan26
 - Lifting Your Loader26
 - Control Levers27
 - Side Dash Controls.....28
 - Before Starting Up.....29
 - Cold Weather Starting30
 - Manoeuvring31
 - Turning31
 - Shutting Down32
 - Parking Brake33
 - Refuelling34

- Accessories35**
 - Led Headlight Kit.....35
 - Reverse Beeper (Optional).....35
 - Warning Light (Optional).....35
 - Horn (Optional)35
 - Back Protection Bars (Optional)35
 - Oil Cooler (Optional)36
 - Emergency Stop (Optional).....36
 - Battery Isolator (Optional).....36

- Operate Loader Attachments37**
 - About Loader Attachments37
 - Safety Guidelines for Attachments37
 - Hydraulic Attachment Connections.....38
 - 4-in-1 Attachment.....39
 - Power Head and Auger Attachments40
 - Trencher Attachment41
 - Bucket Broom Attachment42
 - Rotary Hoe Attachment43
 - Fork Tyne Attachment.....44
 - Angled Backfill Blade Attachment44

- Install Track45**
 - Preparation45
 - Installation45
 - Track Orientation47

- Kanga Handover Worksheets49**
 - Record the Main Component Serial Numbers49
 - Loader Checklist.....50
 - Delivery Sheet & Warranty Registration.....51
 - Inspection and Checks.....49

- Maintain Your Kanga Loader49**
 - Daily Checklist50
 - Loader Arm Maintenance52
 - Long-Term Loader Storage53
 - Storage53
 - Post-Storage and Return to Operation54
 - End-of-Service-Life Disposal.....55

- Perform Service Tasks56**
 - About Service Tasks56
 - Under the Cowling.....57

Engine Oil	58
Engine oil filter	59
Fuel Filter	59
Idle Speed	59
Valve Clearance	59
Spark Plugs	59
Air Cleaner	59
Service Tasks: Hydraulics.....	60
Hydraulic Controls	64
Service Tasks: Vapour Canister	65
Service Tasks: Spark Arrestor.....	65
Service Tasks: Grease Nipples	66
Service Tasks: Battery	68
Service Tasks: Pivot Pins.....	69
Service Tasks: Tilt Chain.....	70
Service Tasks: Tyres and Tyre Pressure.....	71
Service Tasks: Visual Inspection.....	72
Service Tasks: Electrics	73
Service Intervals and Records.....	74
Maintenance Schedule	75
Troubleshooting Guide	77
Arms	77
Hydraulic Pump	78
Drive System	78
Auxiliary Hydraulic	79
Engine.....	79
Loader Specifications and Decals.....	80
Specifications: PW220 Wheeled Loader	81
Schematic: PT220 Loader with Tracks.....	82
Specifications: PT220 Tracked Loader.....	83
Decals: PT220/PW220 Loader	84
PW220 & PT220 Decal Kits	86
Understand Your Warranty.....	87
Terms and Conditions.....	87
Spare Parts Warranty.....	88
Contact Information	89
Index	90

**Kanga Handover Worksheets section is removed, during the Loader Handover.

Identify Your Kanga Loader

Read Your Product Plate

MANUFACTURER: DIGGA AUSTRALIA PTY LTD	
LOADER SERIAL NUMBER: (1)	POWER: (4)
MANUFACTURE DATE: (2)	ROC: (5)
MODEL: (3)	MASS: (6)
ENGINE MAKE: (7)	(8)
ENGINE SERIAL NUMBER: (8)	(9)
EPA ENGINE FAMILY NAME: (9)	(10)
EPA EVAP GASOLINE FUEL SYSTEM FAMILY NAME: (10)	(11) DE-000886

Key

- 1 Mini-Loader Serial Number
- 2 Date of Manufacture (in Australia)
- 3 Full Model Code
- 4 Engine Gross Maximum Power (HP/kW)
- 5 Mini-Loader Rated Operating Capacity (ROC)
- 6 Mass of Loader (without bucket, operator and full fluid capacity)
- 7 Make of Installed Engine
- 8 Engine Manufacturer Serial Number
- 9 EPA Engine Family Name (from engine)
- 10 EPA Family Name of Fuel System (unleaded fuel loaders only)
- 11 Serial Tag Part Number

Understand the Model Number

Your loader's model number provides information about your loader. Compare the number on the machine to the code provided below. The first letter represents the fuel type, Petrol (P).

Second letter indicates either a wheeled (W) tracked (T) loader. The third number identifies the Series and the next two numbers represent the Horse Power Class of the engine.

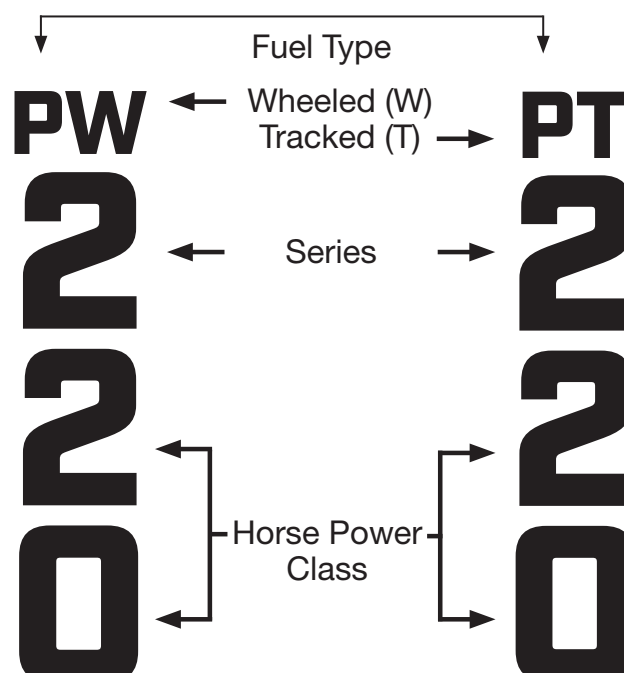

Safety Information

Understand Safety Warnings and Symbols

You must understand all safety statements shown on your loader and in this manual. Especially note information called out by the designations shown below. Following these safety precautions is required when operating or maintaining a Kanga Loader.

DANGER

The **DANGER** designation indicates an imminently hazardous situation that, if not avoided, will result in death or serious injury.

WARNING

The **WARNING** designation indicates a potentially hazardous situation that, if not avoided, could result in death or serious injury.

CAUTION

The **CAUTION** designation indicates a potentially hazardous situation that, if not avoided, may result in minor or moderate injury or property damage.

You will also see information called out with the **NOTE** designation. This additional safety or general information is important to the maintenance and operation of your loader.

This Operator's Manual provides measurements in both International System of Units (SI) and United States customary system units (USCS), displayed as "SI (USCS)."

During day-to-day operation of your loader, you will encounter a variety of situations beyond those listed in this manual. We encourage you to assess the risk present at any job site and in every work task *before* beginning work. Apply appropriate risk mitigation strategies to make safety a first priority at all times, and if these are not sufficient, stop the job and immediately seek the help of a qualified safety consultant.

NOTE





In the diagrams and illustrations shown in this manual, safety guards and covers may have been removed. This is strictly for illustrative purposes. All guards and safety controls must be in place while operating your loader.



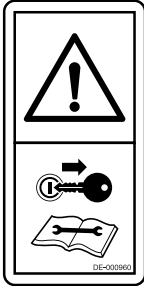

Safety Decal Labels

The following section provides a glossary of safety labels found on your Kanga Loader. These labels are important! Become familiar with both their meaning and location prior to operating your loader.

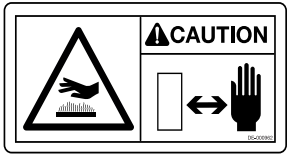
They must be maintained so each decal label is clean, visible, and legible. To clean the decal, use a soft cloth, water, and soap. Avoid the use of solvents, gasoline, or other harsh chemicals, as these may damage the decal.

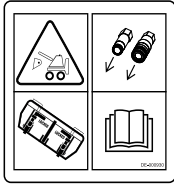
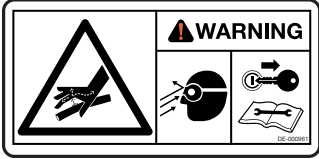
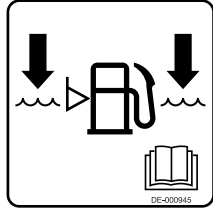
If a safety label has been damaged or removed, it must be replaced. In the Loader Specifications section of this Operator's Manual, refer to "Decals: PT220/PW220 Loader" on page 84 for your loader's decals part number information.

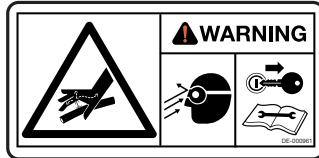
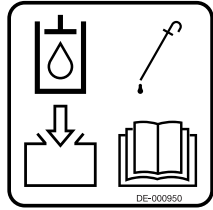
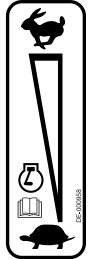
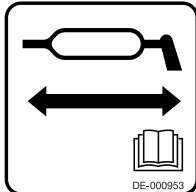
READ OPERATOR'S MANUAL	REMOVE IGNITION KEY	RATED OPERATING CAPACITY
 <p>CAUTION</p> <p>Completely read and understand this operator's manual before using your Kanga loader. Keep the manual with the machine at all times.</p>	 <p>CAUTION</p> <p>Before any maintenance is performed, switch engine off and remove the key. Never leave the key in an unattended machine.</p>	 <p>WARNING</p> <p>To avoid a tipping hazard, do not overload this machine. See "Tipping Load and Rated Operating Capacity (ROC)" on page 16.</p>
CRUSHING HAZARD	CAUSTIC LIQUID	HOT SURFACE
 <p>WARNING</p> <p>The loader arm poses a whole-body crushing hazard. Secure the Arm at all times when carrying out maintenance activities. See "Loader Arm Maintenance" on page 52</p>	 <p>WARNING</p> <p>The 12V battery contains caustic liquid that may result in chemical burns to flesh and materials.</p>	 <p>WARNING</p> <p>Keep hands and body parts a safe distance from the hot surfaces located in the exhaust, engine, and hydraulic areas.</p>

ATTACHMENT CONNECTIONS	FLUID UNDER PRESSURE	SAFE FILL LEVEL
 <p>WARNING</p> <p>Ensure attachment locking pins are engaged and quick couplers are connected before using a loader attachment. See "Hydraulic Attachment Connections" on page 38 for safe hitch connection and safe connection and disconnection of hydraulic hoses.</p>	 <p>WARNING</p> <p>This machine operates on high pressure hydraulic fluid. Always wear eye protection when operating or performing maintenance on this machine. See "Hydraulic Attachment Connections" on page 38 for information on safe connection and disconnection of attachments for hydraulic safety.</p>	 <p>CAUTION</p> <p>Do not overfill the fuel tank. See "Refuelling" on page 34 for refuelling and maximum fuel level.</p>
FLAMMABLE LIQUID	PRESSURE INJECTION INJURY	ENGINE OIL
 <p>WARNING</p> <p>The fuel required for this loader is flammable. Do not refuel while the engine or other surfaces are hot. See "Refuelling" on page 34.</p>	 <p>WARNING</p> <p>Hydraulic Fluid under pressure presents a risk of serious injury. Pressure Injection injury, if not treated immediately could result in amputation.</p>	 <p>CAUTION</p> <p>Hydraulic oil filling point with dip stick level marker. See "Service Tasks: Hydraulics" on page 60.</p>
ENGINE SPEED CONTROL	DAILY GREASE POINT	TYRE PRESSURE
 <p>CAUTION</p> <p>See "Control Levers" on page 27.</p>	 <p>CAUTION</p> <p>Some grease points may be hidden. See "Service Tasks: Grease Nipples" on page 66.</p>	 <p>CAUTION</p> <p>Maintain correct tyre pressure for all loader tyres. See "Service Tasks: Tyres and Tyre Pressure" on page 71.</p>

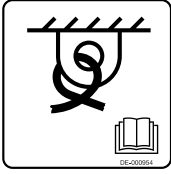
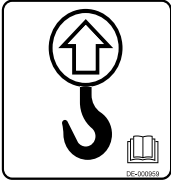
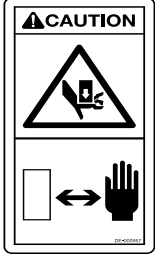
LASHING POINT	LIFT POINT	CRUSHING HAZARD
<div style="text-align: center;">  </div> <p>CAUTION</p> <p>Lash the loader to a trailer or truck from only the locations marked as lashing points. See "Lashing Points" on page 25.</p>	<div style="text-align: center;">  </div> <p>CAUTION</p> <p>Lift the loader only at points approved for lifting. "Lifting Your Loader" on page 26.</p>	<div style="text-align: center;">  </div> <p>CAUTION</p> <p>Keep hands and body parts a safe distance from actuating parts.</p>

Safe Work Practices – Pictograms

These decals illustrate key safety practices related to the operation of your Kanga Loader.



Descriptions

- 1 Caution: Take note of the following safe work practices and safety notices. Always read the operator's manual before operating this machine.
- 2 Warning: Fall hazard.
- 3 Safe Operation Angle: Do not operate machine on slopes greater than 20 degrees.
- 4 Manoeuvre the machine slowly when turning.
- 5 Manoeuvre the machine slowly across rough ground.
- 6 Danger: Electrocutation hazard. Always check for overhead and underground power services.
- 7 Keep 3 meters (10 feet) from overhead services and 2 meters (6 feet) from on-ground utility markings.
- 8 Caution: Entanglement hazard. Always keep both feet on the standing platform and stand in an upright position.
- 9 Only operating personnel may be present on the machine. Never sit or ride on the side, top, or front of the machine.
- 10 Before performing any maintenance, switch engine off and remove the key. Never leave the key in an unattended machine.
- 11 Tipping Hazard: Refer to "Tipping Load and Rated Operating Capacity (ROC)" on page 16. Use a steady, even motion on the control levers; do not jerk the control levers. Carry the heavy end uphill. Always check behind you before reversing the machine.
- 12 Never overload the machine or exceed ROC. See "Tipping Load and Rated Operating Capacity (ROC)" on page 16.
- 13 Always operate the machine with the attachment lowered.
- 14 Always move up and down slopes with the attachment lowered.
- 15 Caution: Entanglement hazard.
- 16 Bystanders must be at least 4 meters (12 feet) from the operating machine at all times.
- 17 Engine exhaust gases can asphyxiate. Ensure adequate ventilation.
- 18 Do not operate the equipment in a non-ventilated space.
- 19 Caution: Crushing hazard to feet and legs.
- 20 Do not place feet under the standing platform. Always keep both feet on the standing platform while operating the machine. When stepping on or off, keep feet clear of rear of machine by 0.5 meters (1.6 feet).
- 21 No smoking, no fire, or open flame on or near this machine.
- 22 Wear hearing and eye protection at all times during operation of this machine.

Practice Safety at All Times

General Safety Rules

Read, remember, and apply the following safety rules during the operation of your Kanga Loader. In addition, complete a thorough risk assessment before loading and unloading the loader, and before beginning work. This will aid in anticipating any unsafe operations or work conditions unique to the job.

Completely read and understand this Operator's Manual and keep it with the machine at all times.

Identify, mark, and delineate all underground utility installations before any work commences.

Establish a traffic control plan with a well-defined and clearly marked loading/unloading and work area.

DANGER

To avoid the risk of struck-by and back-over accidents, ensure all personnel, guests, and passers-by in the work area understand where they can and cannot travel on foot.

Mark the boundaries of the work area with barricades and/or traffic cones before beginning work with the loader.

Plant both feet firmly on the driving platform at all times during loader operation.

NOTE

When carrying loads, the operator's body weight provides additional counterbalance to the weight of the bucket load.

Keep body parts within the confines of the loader.

Never tie or otherwise secure yourself to any part of the machine or attachment.

Do not place feet under the driving platform.

DANGER

Keep hands, feet and clothing away from all moving parts, including hydraulic arms.

Stop completely before changing loader direction from forward to reverse or vice versa.

CAUTION

Failure to stop completely before changing direction can affect loader stability and damage the drive of the loader.

Stop completely before operating other hydraulic controls.

Travel at speeds suitable for the conditions and as determined by the task risk assessment.

Slow loader speed to appropriately match ground conditions, such as rough surfaces or uneven terrain.

Travel at the recommended operating speed between 2/3 and 3/4 throttle.

NOTE

Reduced speeds minimize noise levels dangerous to both the operator and bystanders.

Travel with the bucket low and level to the ground, carrying loads as close to the ground as practicable.

Ensure the machine is fully stopped and shut off before stepping onto or off of the loader.

Use handholds to aid in stepping onto or off of the loader.

CAUTION

Do not use control levers as handholds.

Use only thumbs and forefingers to operate the control levers.

Use a steady, even action to achieve proper control. Do not jerk the control levers.

Avoid distractions during loader operation.

DANGER

Never carry passengers on any part of the loader or its attachments.

Remove the key and chock the wheels when the loader is left unattended and/or unsupervised.

Attach a "Do Not Operate" or similar warning tag in the driver area during service and repairs.

Shut off engine during refuelling.

Do not smoke or use open flame during loader operation or while refuelling.

Do not exceed this loader's Rated Operating Capacity (ROC).

Do not engage in horseplay and other dangerous behaviour while operating the loader or attachments.

WARNING

Avoid touching exhaust, engine parts, hydraulic pipes and fittings, drive chains, friction parts, or guards.

Do not remove safety decals. Replace decals that have become damaged or illegible.

Do not remove safety guarding.

If safety guarding must be removed for repairs or maintenance, replace immediately.

Working on Slopes

Slopes present especially dangerous working conditions. Environmental factors, such as the presence of moisture, snow, ice, or slippery plant material, can affect loader stability. Soil conditions, rough terrain, reduced visibility due to dust, and other factors can impair safe operation. The presence of attachments, the condition and configuration of the machine, the loads being carried, and operator experience also impact work safety.

The Kanga Loader is designed to operate on slopes to a maximum of 20°. Note that this is a maximum; the actual safe slope angle may be lower depending on the factors listed above.

WARNING

Never work on a slope greater than 20°. Always complete a comprehensive assessment of slope conditions and risks before commencing work.

Slope



Avoid traveling with and working the loader across slopes, especially on uneven ground. If traveling across a slope is imperative, the area should be traversed under reduced speed and with extreme caution. Any load should be lowered as far as possible.

DANGER

Your Kanga Loader has been engineered to permit access to restricted areas. The loader's reduced width can affect stability when traveling across slopes.

In addition to the precautions listed here, observe the following safety practices when working on slopes:

- Ensure personnel operating the loader are fully trained and aware of hazards and precautions prior to commencing work on a slope.

- Travel down a slope in reverse, and if carrying a load, reduce speed.
- Do not leave the loader unattended on a slope.
- Do not park the loader on a slope.
- Do not carry a load with the arms raised. Always carry loads with the arms against the chassis, close to the ground.
- Never load or unload the loader on a slope.
- Never attach, change or remove attachments on a slope.
- Slopes are a major factor in loss-of-control and tip-over accidents, which may result in severe injury or death. Operating the machine on any slope or uneven terrain requires extra attention and extreme caution.
- Always operate the machine up and down slopes and loading ramps with the heavy end of the machine uphill and the load close to the ground. The heavy end of the machine will depend on the attachment being used or load being carried. Operating with an empty bucket will make the rear of the machine the heavy end, while a full bucket will make the front of the machine the heavy end. Most hydraulic driven attachments make the front of the machine the heavy end.
- Raising the loader arms on a slope will affect the balance and stability of the machine. Always travel and operate with the loader arms in the lowest possible position when on slopes.
- Establish your own pre-operation procedures and operating rules for when operating on slopes. Your procedures must always include surveying the site/slope prior to operating the machine to determine whether the slope is safe for machine travel and operation. With safety at the forefront of your decision making, use good judgment and common sense when completing the slope/site survey.
- Slow down and use extra care on slopes. Take into consideration the ground conditions, weather conditions, surface type, surface condition and available traction which can all affect the stability of the machine. Always proceed slowly, ensuring all movements are smooth and gradual. Never make sudden changes in direction, speed or arm movements.
- Avoid starting or stopping on a slope as this may cause the machine to lose traction.
- Avoid travelling across or turning on a slope. Always proceed straight up and down a slope with the heavy end of the machine uphill.
- Always use extra caution when operating your mini loader near ditches, embankments, waters edge and culverts.

Tipping Load and Rated Operating Capacity (ROC)

In accordance with ISO 14397-1:2007(E), the tipping load was determined by the load that when put in the bucket or fork will commence tipping of the machine. This load has been determined for a range of attachments with the tabulated results on the following pages. As per the code, Tipping Load was determined with:

- The load acting through the centre of bucket volume or in the centre of the fork tynes
- The boom in the least stable position
- A 75kg (165 lb) operator
- Fluids at recommended levels
- A full fuel tank
- Air-filled tyres

NOTE

The water filled tyres is the usual configuration in Australia, however air filled was used as a conservative measure. Optional counterweight mass is not included unless stated.

Rated Operating Capacity (ROC):

ISO 14397- 1:2007(E) states that the Rated Operating Capacity (ROC) is the Tipping Load multiplied by stability factors for normal operation. For skid steers, these factors are 0.50 for wheeled machines and 0.35 for tracked / crawler machines. On certain loaders, Kanga uses what is called an Over Tyre Track (OTT) system. This system is intended to improve traction and float in soft wet conditions, while maintaining the hard / uneven ground stability attributes of a wheel loader. In terms of stability, Kanga find the OTT system to be comparable to a wheel loader though have reduced the factor to 0.45 as an added precaution.

Only Kanga designed and approved attachments are to be used in conjunction with your Kanga Loader. Operator to ensure the attachment is suitable for use with the loader model type and will not cause tipping. Contact Kanga for specific attachment details.

2 SERIES - PW220

BUCKETS						
Material load for buckets	No bucket 0kg *		40kg Kanga GP Bucket		92kg Kanga 4in1 bucket	
Tipping load	357 kg	785 lb	317 kg	697 lb	265 kg	582 lb
Rated Operating Capacity (ROC)	178 kg	392 lb	158 kg	348 lb	132 kg	291 lb

FORKS		
Material load for forks**	500mm Kanga fork tynes	
Tipping load	224 kg	493 lb
Rated Operating Capacity (ROC)	112 kg	246 lb

*This is to represent the general loader capabilities. Cannot be used for material load without adjusting for the bucket mass.

** Tipping Load and ROC are based on stability only. Refer to the fork tyne specifications / manuals for individual arm load capacities.

2 SERIES - PT220

BUCKETS						
Material load for buckets	No bucket 0kg *		40kg Kanga GP Bucket		92kg Kanga 4in1 bucket	
Tipping load	361 kg	794 lb	321 kg	706 lb	269 kg	591 lb
Rated Operating Capacity (ROC)	162 kg	357 lb	144 kg	318 lb	121 kg	266 lb

FORKS		
Material load for forks**	500mm Kanga fork tynes	
Tipping load	227 kg	500 lb
Rated Operating Capacity (ROC)	102 kg	225 lb

* This is to represent the general loader capabilities. Cannot be used for material load without adjusting for the bucket mass.

** Tipping Load and ROC are based on stability only. Refer to the fork tyne specifications / manuals for individual arm load capacities.

Before You Dig

Never begin work at a new location until the work area has been fully marked for underground utilities. Buried electrical cable, telephone wires, gas, water and sewer lines are likely to be present. Unintentionally disrupting these hidden hazards while working with your loader can result in dangerous situations and property damage.

Many countries offer a similar “Before You Dig” service to Australia, which advises the location of underground services in your area. If available also use this service prior to digging, drilling, trenching or any form of excavating and earthmoving.

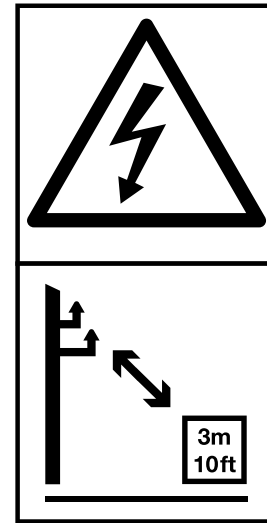

CAUTION

You must ensure that underground utilities have been officially marked out before working in the area. Markings must be valid according to state law or practice.

To begin the process of utility location, log on to the respective “Before You Dig” authority for your Country or State, several days before work is set to begin. You can request the necessary information on the utility services in that area.

Be ready to provide information about where you plan to dig, the type of work involved, and how you can be reached. An asset plan can be provided to ensure zero damage to assets can occur.

The applicable utility companies may also be informed, and utility locator personnel may be sent to the property to mark the approximate locations of the underground utilities. They may use paint, flags, stakes, or other temporary methods.

While operating your loader and attachments in a marked area, keep a distance of at least 2 meters (6 feet) from all underground services.

DANGER

During loader operation, maintain a minimum “no-work zone” buffer of 3 meters (10 feet) from any overhead electrical service and 2 meters (6 feet) from any underground service.

Personal Protective Equipment (PPE)

All personnel working on or near the Kanga Loader must follow the work site's Health and Safety guidelines and wear a hard hat, hearing protection, safety glasses, and other protective equipment, as appropriate for the hazards present.



 **WARNING**
Avoid loose clothing or jewelry that can snag on controls or on other parts of the equipment.

NOTE
After all the engineering and administrative controls have been exhausted, PPE is considered the last line of defense against Injury. Wear the correct PPE at all times while operating the Kanga Loader.

Complete a Risk Assessment

Five Steps to an Effective Risk Assessment

Your Kanga Loader is a versatile machine, capable of performing a variety of tasks in a safe and effective manner. To ensure the safety of operators and others, it is important to document the work at hand for hazards and risk. Before beginning work, complete a risk assessment. The following steps provide a framework for this activity:

1	<p>Document the Activity</p> <p>Assemble those involved in the activity. Write down the tasks required for the activity in step-by-step form.</p>	<p>The following are examples of hazards that may be present at your work site:</p> <ul style="list-style-type: none"> • Overhead power lines • Underground utilities • Excavations • Slopes or adverse cambers • Confined spaces • Poor or limited sight lines and visibility • Roadways carrying vehicular traffic <p>People or animals accessing the work area or machine</p> <p>Note other hazards here:</p> <table border="1" style="width: 100%; height: 100%;"> <tr><td> </td></tr> <tr><td> </td></tr> <tr><td> </td></tr> <tr><td> </td></tr> <tr><td> </td></tr> <tr><td> </td></tr> <tr><td> </td></tr> <tr><td> </td></tr> </table>								
2	<p>Identify the Hazards (see list, right)</p> <p>Next to each task, identify what part of the task may cause injury to those engaged in the task or others in the vicinity. Rate the consequences and likelihood of the hazard using the risk assessment matrix on the next page.</p>									
3	<p>Document the Control Measures</p> <p>Using the results from the risk assessment matrix, determine which hazards require attention. List all mitigation measures that are required to eliminate or minimize those hazards.</p>									
4	<p>Identify the Responsible Person</p> <p>Document the name of the person responsible for implementation of the mitigation measure.</p>									
5	<p>Monitor and Review</p> <p>Ensure that the activity is supervised and that the documented process is being followed. When a documented activity changes, when there is a change of personnel, or after an appropriate length of time, review the documentation.</p>									

Should an incident occur, conduct an investigation to determine hazards, the underlying causes, and any safety-related strategies that may be needed. In this way you can work to prevent future occurrences.

Risk Assessment Matrix

CONSEQUENCES	RATING	LIKELIHOOD	RATING
Catastrophic Catastrophic injury, injuries resulting in single or multiple deaths or permanent disablements	5	Almost certain May occur several times a year/can happen almost every time the activity takes place/almost all employees are exposed to the hazard	5
Major Major injury, fatality, serious bodily injury or illness caused by work- permanent incapacitate	4	Likely May occur once or several times during the life of the activity / many employees are exposed to the hazard	4
Moderate Moderate injury or illness- injury requiring casualty treatment- Lost time injury	3	Possible Low possibility that it may happen in the life of the activity / some employees are exposed to the hazard	3
Minor Minor injury- first aid treatment without absence- medical treatment injury	2	Unlikely Only a remote risk that it may happen in the life of the activity / few employees are exposed to the hazard	2
Negligible Small injury or bruises- first aid treatment	1	Very Unlikely No knowledge of similar situations happening elsewhere / only a few employees are exposed to the hazard	1

Likelihood	CONSEQUENCES				
	Negligible	Minor	Moderate	Major	Catastrophic
5 Almost certain	11	16	20	23	25
4 Likely	7	12	17	21	24
3 Possible	4	8	13	18	22
2 Unlikely	2	5	9	14	19
1 Very Unlikely	1	3	6	10	15

Risk Control Legend - Outcome

23 to 25 = Extreme Risk - Cease activity immediately and implement risk controls before restarting work activities. Consult with competent and qualified personnel to make the work area safe.

15 to 22 = High Risk - Plan and implement risk control measures after performing the five-step risk assessment. Seek advice from the manufacturer if any doubt remains.

7 to 14 = Medium Risk - Acceptable but remedial work may be required in the longer term.

1 to 6 = Low Risk - Acceptable without further remedial work. However, you should still monitor and review periodically.

Be Work-Ready

Before beginning work, answer the following questions. Immediately address any issues detected during this process.

Perform a Site Assessment

- Is the terrain stable and suitable to work on?
- Have you conducted a thorough site inspection before entering the area with loader?
- Are wet or boggy conditions present?
- Are other environmental factors affecting loader operation present?
- Is the work area sloped?
- Are slope angles within safe recommendations?
- Have underground utilities been marked and the no-work zone specified?

Ensure Personal Safety

- Are all safety instructions clearly understood by all individuals working on and around the loader?
- Are all personnel wearing recommended and appropriate PPE?
- Is the loader operator fully prepared to use the loader as specified in the operator's manual?
- Has the daily pre-operation inspection of the loader been completed?
- Have issues detected during the pre-operation inspection been addressed?
- Are all loader safety features operable?
- Are the attachment locking pins fully engaged and secure?
- Is the driving platform clean, dry, and free from grease, mud, or other slip risks?

Execute the Task

- Have any required risk mitigation strategies been put in place?
- Has a safe and logical sequence of work been specified?
- Has the plan of work been discussed with all personnel and bystanders in the area?
- Has work been coordinated with other trades and activities on the site?
- Has the work area been clearly demarcated?
- Do work plans reflect the weight or load and operational limitations of the loader?
- Have all operators been reminded to travel with loads low to the ground?
- Do operators understand that the bucket must be in the down position when not in use?

Operate Your Kanga Loader

Inspection After Delivery

As soon as your loader is delivered and before declaring it ready for use, thoroughly inspect it for any evidence of damage resulting from shipment.

CAUTION

The task of preparing a new loader for use should be completed by a responsible person who has read and understood this manual.

Care and maintenance requirements for your loader are simple, and coupled with the use of common sense, a general occupational health and safety knowledge, and a daily prework visual inspection, should not pose any problems. The following checklist provides suggestions for detecting defective or damaged parts.

Check Before Using

1	Inspect the machine chassis for any visible damage.
2	Visually inspect all components to ensure they are securely attached.
3	Inspect all areas for evidence of hydraulic oil, engine oil, or fuel leakage.
4	Inspect arm assembly area for firm attachment and sufficient lubrication. Check hydraulic cylinders for oil leakage and visible damage.
5	Check hydraulic oil lines for correct connections and for signs of leakage.
6	Check wheel and tyre assemblies for loose or missing wheel nuts, any visible damage, and proper tyre inflation.
7	Check wheel drive motor assemblies for any visible damage and oil leakage.
8	Inspect all cylinders for rust, nicks, scratches, or foreign material on shafts. Check for hydraulic oil leaks at the seal and fitting areas.
9	Inspect the engine compartment for loose or missing components and any evidence of damage or leakage.
10	Check the engine oil level is within operating limits as marked on the dip stick.

Loading and Unloading

Carefully observe the following safety guidelines during the loading, unloading, and trailering of your Kanga Loader.

When loading or unloading the machine from a trailer, the trailer must be located on a firm, even and flat surface. It must remain fully attached to the towing vehicle.



CAUTION

Never unload a trailer positioned on a slope. Do not park or leave the loader on a slope.

Ensure the angle of the loader during ascent or descent from the trailer is within safe operational limitations.

Carry out all loading or unloading manoeuvres at a slow speed, with due care for personal safety and damage to equipment.

NOTE

As necessary, practice the loading or unloading manoeuvres in a safe location until the process is mastered.

Unloading

1. Ensure trailer and towing vehicle are on firm and level ground.
2. The trailer tow hitch must always be engaged and locked onto the tow ball during unloading and loading.
3. Make sure the tow vehicle is in gear and parked with the handbrake applied.
4. Ensure that the trailer safety brake is applied.
5. Adjust rear stabiliser legs to contact the ground.
6. Lower the ramps on the trailer.
7. Remove the load binders/or ratchet straps as follows:
8. *From the tie down points located between the wheels on the left and right hand side.*
9. *From the tie down points at the rear of the loader on the left and right hand side.*

10. Start the loader as per operating Instructions.
11. Keep the arms on the chassis of the loader and Roll back the bucket using crowd and tilt lever. Always keep the bucket on when unloading
12. Drive back slowly to the edge of the trailer and align the loader wheel with the ramps proceed to reverse the loader down the ramps at a slow and consistent speed.
13. Drive the loader clear of the ramps.
14. Park the loader on flat level ground with the bucket lowered flat on the ground. See "Shutting Down" on page 32 and "Parking Brake" on page 33.

Loading

1. Ensure trailer and towing vehicle are on firm and level ground.
2. The trailer tow hitch must always be engaged and locked onto the tow ball during unloading and loading.
3. Make sure the tow vehicle is in gear and parked with the handbrake applied.
4. Ensure that the trailer safety brake is applied.
5. Adjust the rear stabiliser legs to contact the ground (if provided).
6. Lower the ramps on the trailer.
7. Keep the arms on the chassis of the loader and roll back the bucket using crowd and tilt lever. Always keep the bucket on when loading.
8. With the bucket facing the tow vehicle align the wheels with ramps
9. Drive the loader forward up the ramps at a slow and consistent speed.
10. With the loader squarely on the trailer, lower the bucket using the tilt and crowd lever so the bucket rests flat on the trailer deck, then slowly drive the loader forward into the bucket stop on the trailer.
11. When correctly positioned, shut-down the loader and apply the park brake (see "Shutting Down" on page 32 and "Parking Brake" on page 33).

NOTE

Always shut off the fuel petcock valve when transporting your Kanga Loader, as the vibration might cause fuel to flood the engine and damage it.

12. Inspect the lashing points on the loader and on the trailer for bolt tightness, excessive wear or visible cracking.

DANGER

The loader must be securely lashed to the trailer during transport. Failure to prevent loader movement may cause injury or death to yourself or others.

13. Inspect all lashing gear for excessive wear and make sure the inspection tags are up to date.
14. Lash the loader according to the "Lashing Plan" on page 26 using the lashing gear and lashing points indicated.
15. With the loader and attachments secured for transport, raise and secure the trailer ramps.
16. Check the lashing conditions before departure and periodically during the transport.

Lashing Points

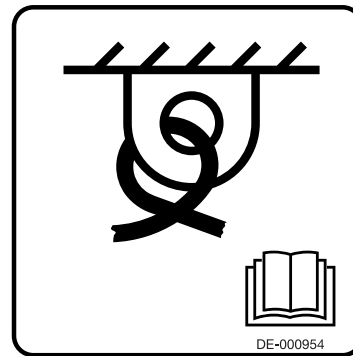

CAUTION

Lash the loader to a trailer or truck only from the locations marked as lashing points. Read and understand this operator's manual prior to transporting your loader.

Your Kanga loader has four lashing points, two on each side. Each lashing point is indicated with the following safety label:

Safety in the Work Zone

In all work zones, it is important to control both vehicle and foot traffic in the area.

Always use cones, signage, and other signals to demarcate the unloading and loading zone. Ensure that non-essential personnel and bystanders are sufficiently clear of the area before proceeding with the loading or unloading process.

DANGER

Observe extra vigilance when loading, unloading, or working with your loader close to roadways carrying traffic. Never count on drivers to slow down, stop, or otherwise accommodate your presence.

Lashing Plan

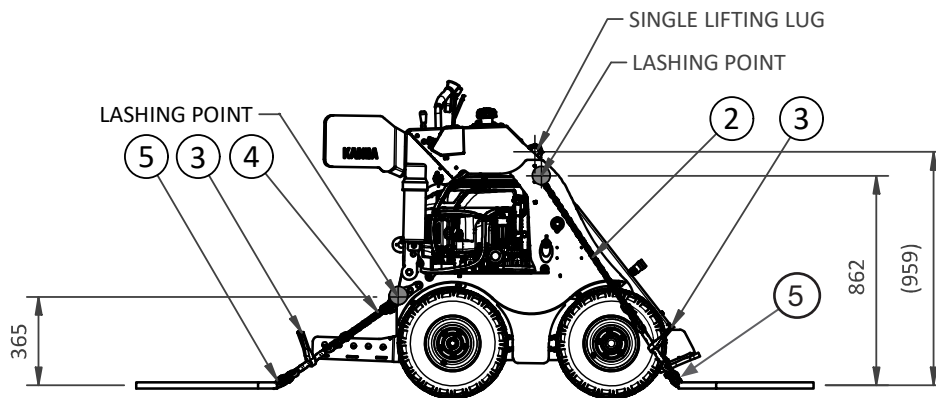
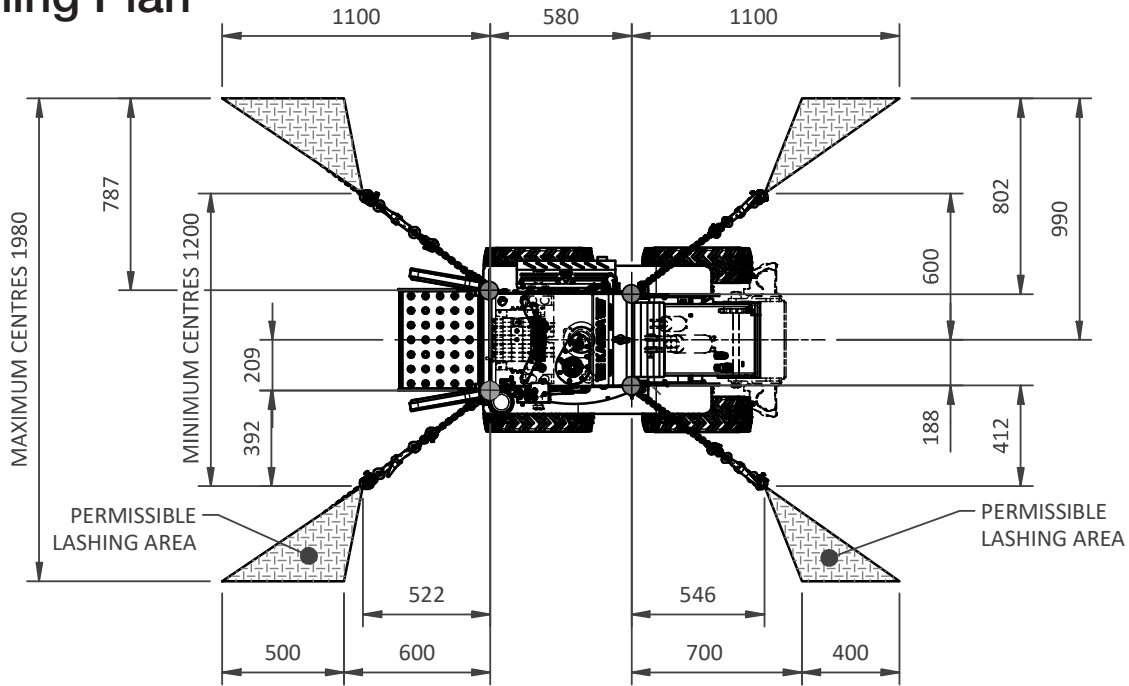

ITEM	QTY	DESCRIPTION
2	2	Chain 6mm G-70
3	4	Loadbinder Ratchet Grab 6mm
4	2	Chain Sling 6mm with Clevis Hook and Latch (see figure)
5	4	Bow Shackle 1.5 TONNE

All lashing gear must have at least 1500Kg (3300 lbs) lashing capacity.

Item 4



Lifting Your Loader

When lifting the machine, use appropriately rated slings and shackles. These must be attached securely to the lifting point on the top of the machine. The hook of the crane must swivel to prevent inadvertently unscrewing of the lifting eye bolt. The lifting eye must be adequately tightened with full thread engagement prior to commencing any lifting/rigging of the loader.

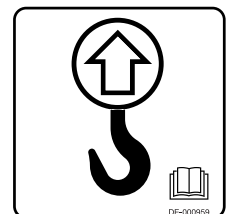

! DANGER

For the Kanga Series 220 Loader. The load on the lifting lug must not exceed 600Kg (1320 lbs).

Control Levers

Spring-centered levers sit on the top face of the loader control area. These control the basic operating functions via a push-pull action. The levers and their corresponding functions are illustrated here.

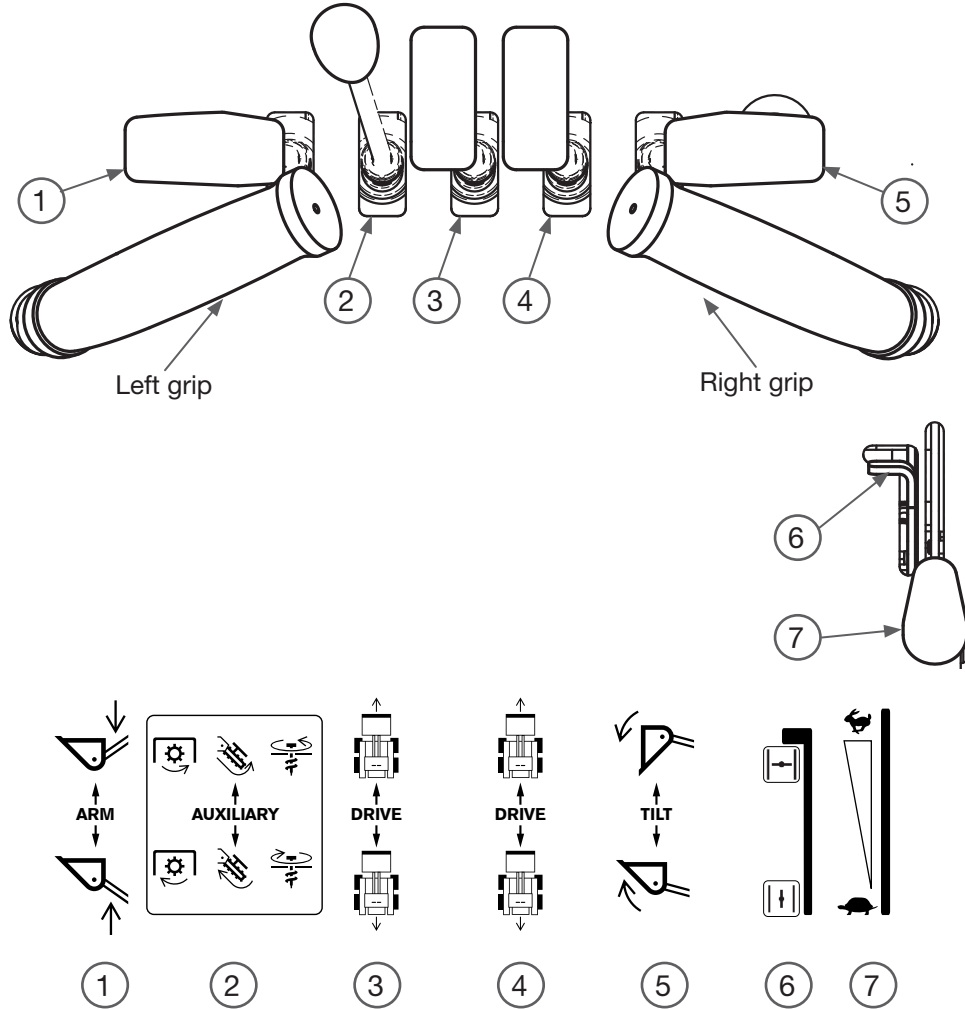

Lever	Controls	Action on PUSH	Action on PULL
1	Main lift arm control	Lower Arm	Raise Arm
2	AUX Motor	AUX Motor Reverse	AUX Motor Forward
3	Left Drive	Forward Simultaneously Applied	Reverse Simultaneously Applied
4	Right Drive		
5	Tilt	Forward (tip)	Reverse (crowd)
6	Choke Control	Close	Open
7	Throttle	Faster Travel	Slower travel

Side Dash Controls

The side dash is located on the right hand side, and features electric controls and instrument lights.

1 - Ignition Switch

The ignition switch is turned with one of the 2 keys supplied with your Kanga Loader. It has 3 positions:

OFF - Shuts off the engine and instrument lights and stops the hour-meter. The key can be inserted and removed only in this position.

ON - This is the normal ignition switch position when operating your Kanga Loader. The instrument lights come on and the hour-meter accrues working hours in this position.

START - Use this position only to start the engine. The switch returns to the ON position once you release the ignition switch. Do not keep the switch in this position for more than 5 seconds at a time as it might overheat the starter motor. The warning lights should turn off once the engine has started successfully, unless there is an abnormal condition (see below).

2 - Hour-meter

The hour-meter display registers working hours for maintenance purposes. See "About Service Tasks" on page 56.

3 - Battery Warning Light

Indicates the electric system voltage is low, meaning that the battery is not being correctly charged and the engine might fail to restart. Check the electric system immediately.

4 - Oil Warning Light

Indicates that the engine oil pressure is low. Stop the engine immediately if this light turns on.

5 - Headlight Switch

Operate the headlights. See "Accessories" on page 35.

OFF - Headlights off

ON - Headlights on.

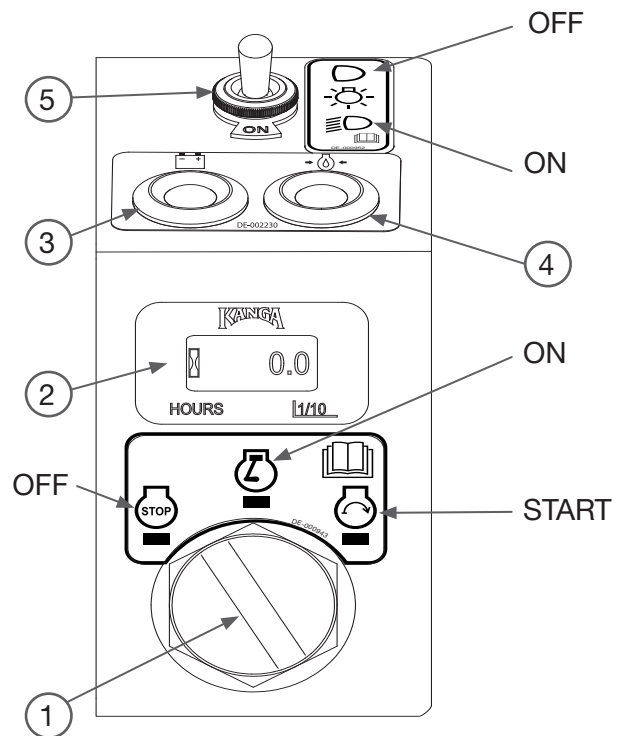

Before Starting Up

Before starting up, the operator must be familiar with the content of this manual and understand all safety procedures (see "Safety Information" on page 8 and "Practice Safety at All Times" on page 13), then complete the following steps:

Check the fuel level and fill up if necessary (see "Refuelling" on page 34). Ensure that the fuel is the correct type, free from impurities or water.

Check that both the crankcase oil and hydraulic oil levels are within operating limits (see "Engine Oil" on page 58 and "Service Tasks: Hydraulics" on page 60).

Finally, complete the "Daily Checklist" on page 50. With all items checked and compliant, you are ready to start working.



CAUTION

Check that all control levers are in the neutral, centre position before starting the loader.

NOTE

Ensure AUX lever has automatically returned to the "N" position from the "F" or "R" position. If this lever is not in neutral, the engine will attempt to start under full load, placing a strain on the starter motor and draining the battery.

Starting

After completing the "Daily Checklist" on page 50 you are able to start the Kanga Loader:

1. Open the fuel flow moving the petcock valve to the ON position (see "Shutting Down" on page 32).
2. Turn the battery isolator switch (if equipped) to the ON position (see "Accessories" on page 35)
3. Ensure the Emergency Stop button (if equipped) is not activated. If so, release it turning the button clockwise 1/4 of turn (see "Accessories" on page 35).



CAUTION

Check that all control levers are in the neutral, centre position before starting the loader.

4. Stand on the driving platform and grab at least one of the grip handles.
5. Ensure all control levers are in the neutral centre position.
6. To start a cold engine, push the choke lever to the CLOSE position. To restart a warm engine, leave the choke lever in the OPEN position. See "Control Levers" on page 27.
7. Move the throttle lever from the SLOW position, about 1/3 of the way toward the FAST position.
8. Turn the ignition switch to the ON position. The warning lights must come on.
9. Operate the starter motor turning the ignition switch to the START position and holding it there until the engine starts. If the engine fails to start within 5 seconds, release the ignition switch and wait at least 10 seconds before a new attempt.

NOTE

Using the START position for more than 5 seconds at a time will overheat the starter motor and can damage it.

10. When the engine starts, both warning lights should turn off. See "Side Dash Controls" on page 28.

11. Warm up the engine for 2 or 3 minutes.
12. If the choke lever was moved to the CLOSE position to start the engine, gradually move it to the OPEN position as the engine warms up.
13. Release the parking brake (see "Parking Brake" on page 33).
14. Commence work.

NOTE

The operator must not move any of the control levers until he or she is standing with both feet on the driving platform and holding the grip handles, and has confirmed no people or obstacles are in the path of the loader.

First-time or novice users should employ a slow, 1/3 throttle to practice safe operation before commencing work. The recommended normal operating speed of the machine is 2/3 to 3/4 throttle.

The standing position is a safety feature which allows a quick exit from the machine in case of an emergency. For this reason, the loader is not fitted with a seat belt.

Never limit the operator's ability to safely exit from the loader. Do not add an after-market safety restraint system to the machine.

Cold Weather Starting

- Do not allow the starter motor to run continuously for more than 5 seconds.
- Be sure to warm up the engine, not only in winter, but also in warmer seasons. An insufficiently warmed-up engine can shorten its service life.
- When there is fear of temperature dropping below -15°C (5°F) detach the battery from the machine, and keep it indoors in a safe area, to be reinstalled just before the next operation.

Manoeuvring

Manoeuvring is made possible by individual control of the hydraulic motors on each side of the machine. The left drive control lever (3) and the right drive control lever (4) are used for manoeuvring.

Think of these levers as softly operated clutches for engaging and disengaging the wheels or tracks. Use slow, even movements of the control levers for smooth operation of the loader.

NOTE

If an operator is unfamiliar with the loader's operation, he or she should practice slow starts, gentle stops, and controlled turns in an open, safe area prior to beginning work.

NOTE

Please refer to "Working on Slopes" on page 14 for information on MANOEUVRING on slopes.

CAUTION

Always ensure that the attachment locking pins are fully engaged at all times.



Turning

When the power and/or direction on one side of the loader is different from that on the other, the loader will turn. For example, applying forward power to one side and equal reverse power to the other will cause the loader to turn by its own length.

While moving forward, a gentle turn to the left or right can be achieved in two ways. The power can be slightly increased on the side opposite the

turn or it can be decreased on the turning side. This mode of steering allows the type of turn to be chosen to suit the situation.

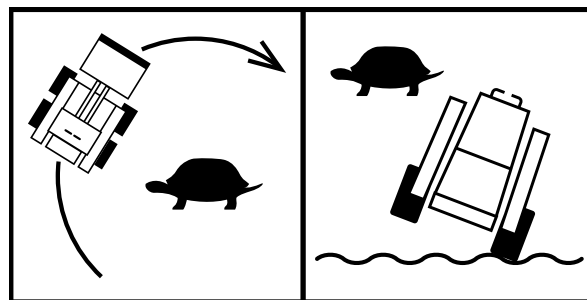

Always Manoeuvre the machine slowly during turns or when traveling across rough ground.

NOTE

Please refer to "Working on Slopes" on page 14 for information on TURNING on slopes. If you must cross a slope, keep the load close to the ground and travel at reduced speed.

NOTE

If you must travel down a slope, do so in reverse.

DANGER

Exercise extreme care on sloping terrain. Avoid traveling or working across a slope.

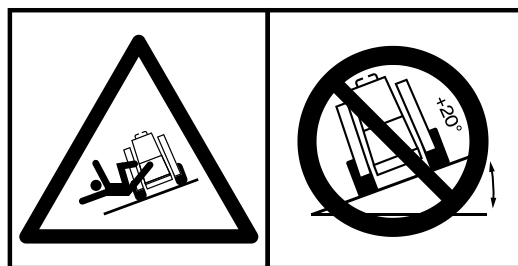

Shutting Down

To shut down your Kanga loader:

1. Select a levelled ground to stop the loader.
2. Lower any bucket or attachment fully to the ground.
3. Reduce the engine speed to idle pulling the throttle lever to the position SLOW.
4. Turn the ignition key to the position OFF.

NOTE

Do not use the Emergency Stop Button (if equipped) to shut the engine off in normal situations.

5. Close the fuel flow turning the petcock valve to the position OFF.
6. If your Kanga Loader headlights are ON, turn them off by moving the switch to OFF position (see "Accessories" on page 35).
7. Turn the Battery Isolator Switch (if equipped) to

the position OFF (see "Battery Isolator" on page 32).

8. Engage the parking brake. See "Parking Brake" on page 33).
9. Remove the key from the ignition switch to prevent unauthorised use.

NOTE

Always shut off the petcock valve to prevent fuel from flooding the engine.

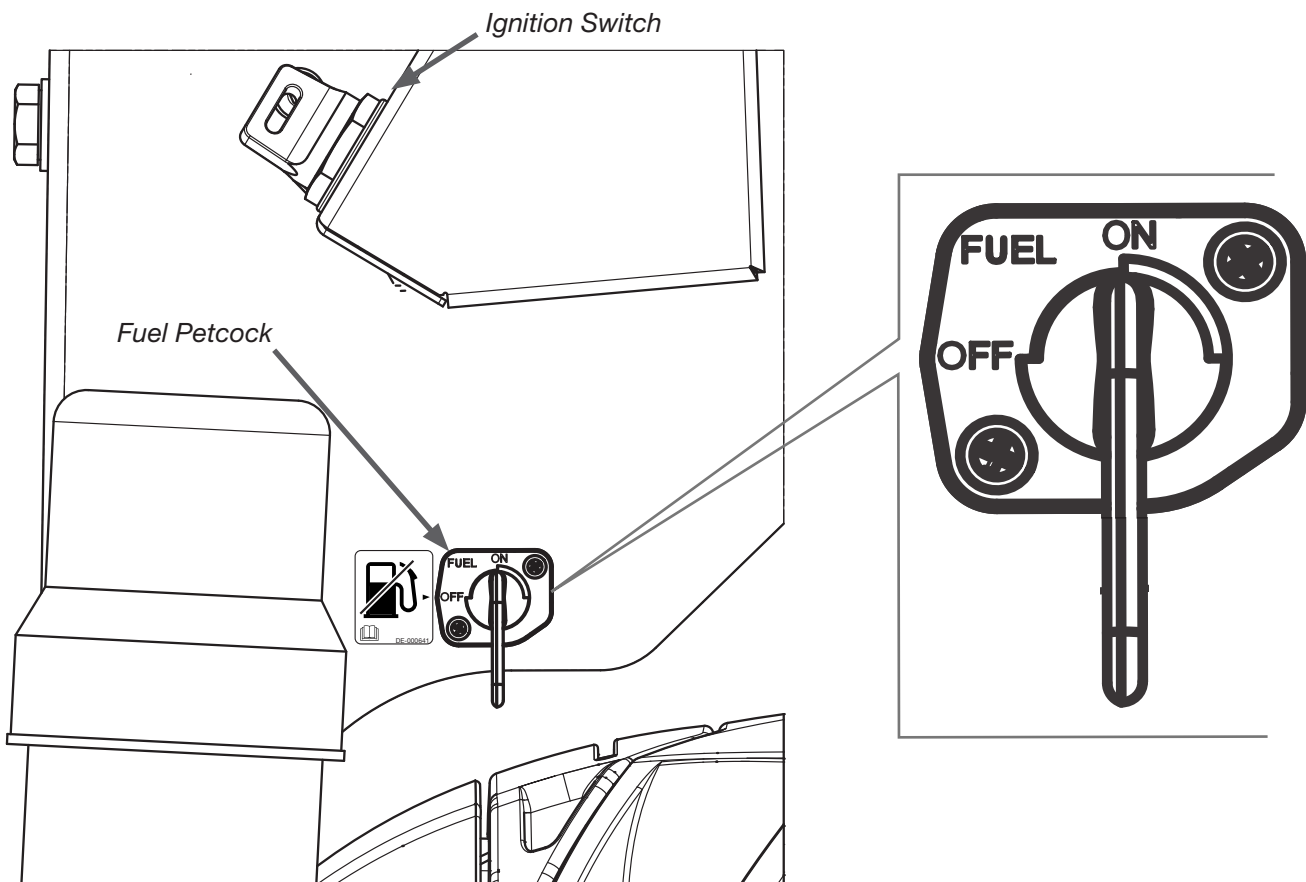
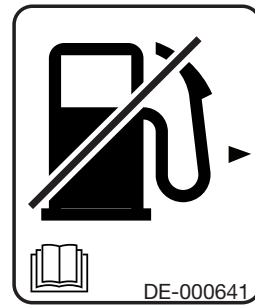

Parking Brake

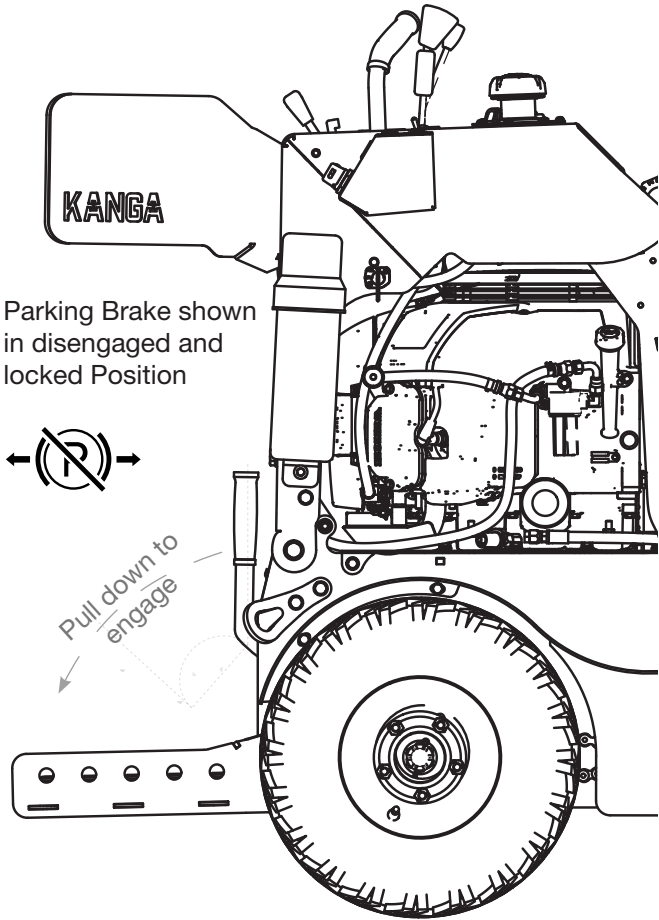

Parking Brake shown in disengaged and locked Position

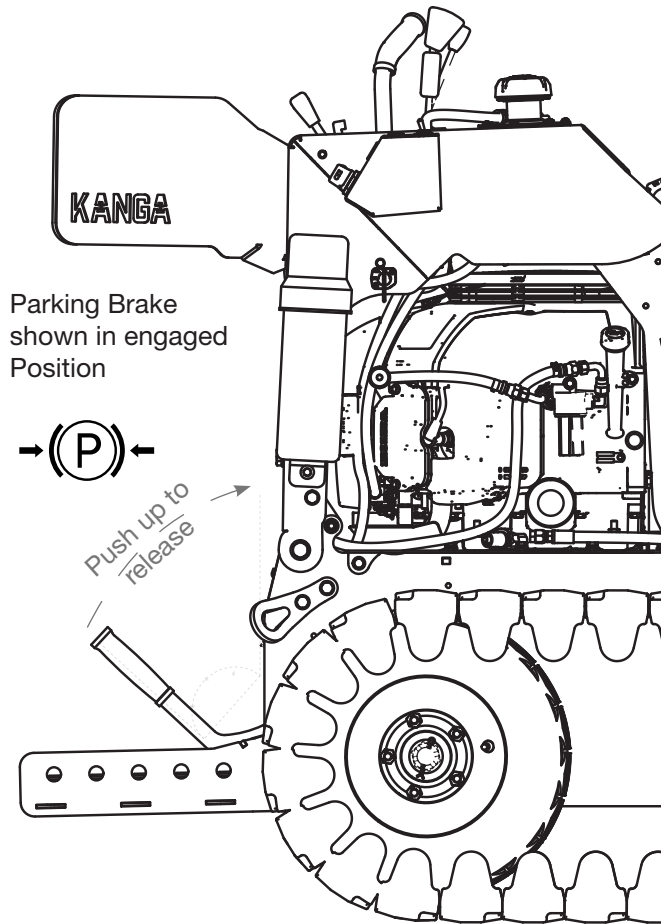

Parking Brake shown in engaged Position

NOTE:
To engage the parking brake, move the lever to the right and then pull down.

NOTE:
To disengage the parking brake, lift the lever up until it snaps into the locked position.

CAUTION

The parking brake might allow the loader to move up to 300mm (1 ft) before engaging. Make sure the parking brake is engaged before leaving the equipment.

CAUTION

Dirty and lack of lubrication might prevent the parking brake pin from actuating. Grease the parking brake mechanism frequently (see "Service Tasks: Grease Nipples" on page 66) and ensure the parking brake is engaged before leaving the equipment.

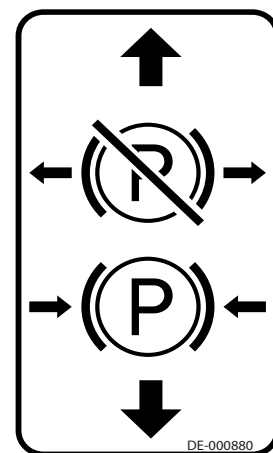

This decal is shown as item 44 on page 84. (Located adjacent to the park brake lever on the rear panel of the loader)

Refuelling

Refuel in a well-ventilated area with the engine stopped (see "Shutting Down" on page 32) and the parking brake applied (see "Parking Brake" on page 33).

Avoid refuelling while the Kanga Loader is over a truck or trailer tray. Always fully lower any attachment or bucket to the ground to discharge static electricity.

Never refuel the engine in an enclosed space or where petrol (gasoline) fumes may reach flames or sparks.

Recommended Fuel

The Honda GXV690 Engine is certified to operate on unleaded petrol (gasoline) with a pump octane rating of 86 or higher (a research octane rating of 91 or higher).

Unleaded petrol (gasoline) containing no more than 10% ethanol (E10) or 5% methanol by volume can be used. See Honda Engine Manual for more information.

Never use stale or contaminated petrol (gasoline) or any fuel mixture. Avoid getting dirt or water in the fuel tank.

Refuelling procedure

If the engine has been running, allow it to cool. Wearing all required PPE, open the fuel cap and check the fuel level. Be mindful of fuel vapours when opening the fuel cap.

Refuel carefully to avoid spilling fuel. Do not refill over the level indicated on the max fuel level decal. See "Specifications: PW220 Wheeled Loader" on page 81 and "Specifications: PT220 Tracked Loader" on page 83 for fuel tank capacity.

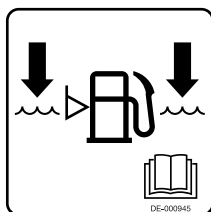

After refuelling, tighten the fuel tank cap until it clicks three times. Keep fuel away from appliance

pilot lights, barbecues, electric appliances, power tools, etc.

Spilled fuel is not only a fire hazard, but also causes environmental damage. Contain and wipe up spills immediately. Follow local Environmental Regulations to dispose of contaminated soil and containment materials.

DANGER

Petrol (gasoline) is highly flammable. Allow the engine and muffler to cool down before refuelling. Follow all safety instruction described above.



**FLAMMABLE
LIQUID**



Accessories

Your Kanga Loader might be fitted with several features to address your organisation's specific requirements. The following items are not installed by default and should be requested when ordering your Kanga Loader. Consult your local branch about installing original accessories to your Kanga Loader.

Led Headlight Kit

The loader can be equipped with headlights to assist the operator in low visibility settings. The led headlight kit comprises of two adjustable 18W round headlights operated through a switch on the side dash (see "Side Dash Controls" on page 28). The beam direction can be adjusted (loose and tight the headlight bolts as required).

CAUTION

Do not rely solely on the headlights to work in the dark. Always ensure adequate lighting to operate.

Reverse Beeper (Optional)

The reverse beeper produces an intermittent beep always when any one of the drive levers (see "Control Levers" on page 27) is pulled towards the operator (rearward drive). The beeper is located under the cowling on the left-hand side.

CAUTION

Do not suppress the rearward beeper.

Warning Light (Optional)

The loader can be equipped with a flashing warning light to improve its visibility and comply with specific organisational safety requirements. Consult your Kanga Dealer for more information.

Horn (Optional)

The horn is used to warn bystanders and other operators nearby. It is activated by a momentary push button on the dash's left side. The horn is located under the cowl on the left-hand side. Always follow your organisation's procedure for horn use.

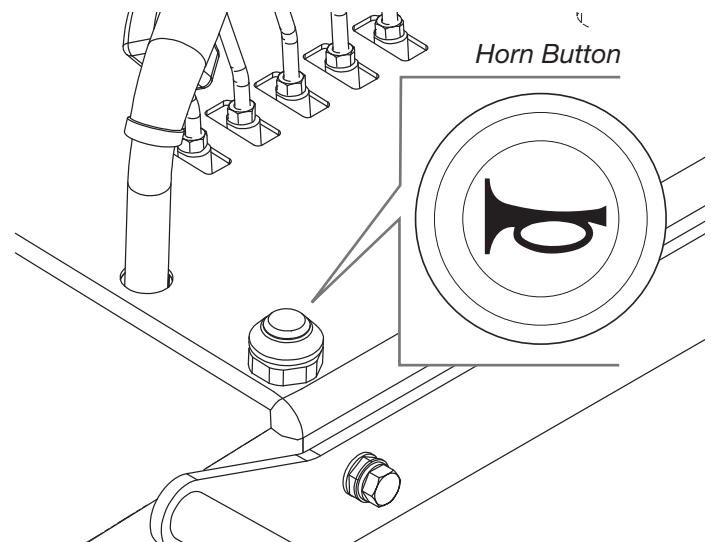

Back Protection Bars (Optional)

All Kanga Loader 2 series are equipped with standard side protection padded 'wings' on both sides of the standing platform. On request, these 'wings' can be replaced with bolted back protection bars. Consult your Kanga Dealer for more information.

Oil Cooler (Optional)

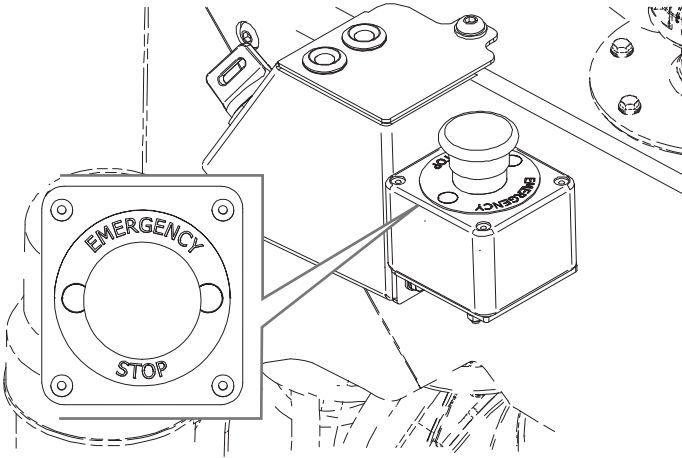

Using your Kanga Loader in extreme conditions might require the installation of a hydraulic oil cooler. Consult your Kanga dealer for more information.

Emergency Stop (Optional)

An emergency stop button can be fitted to the Kanga Loader to comply with specific organisational safety requirements. The emergency stop is located in front of the side dash and shuts off the engine when pressed. To reset the emergency stop, twist the button clockwise.

CAUTION

Always keep the emergency stop accessible and in good operational condition.

Battery Isolator (Optional)

The battery master isolator switch is located beside the battery and is accessible through an opening on the battery cover. It allows to shut off all the electric system.

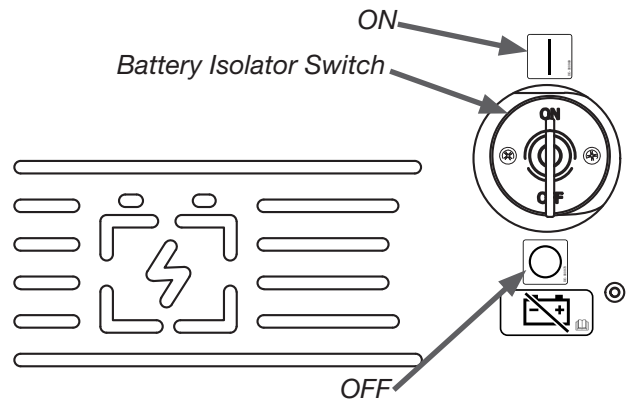
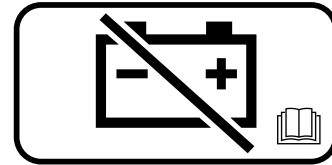

REPLACEMENT PARTS	
Description	Part Number
Headlight Led 18W	EC-100181
Toggle Switch - Headlight	EC-100182
Toggle Switch Silicone Boot	EC-100160
Beeper - Reverse 97dB	EC-001121
Reverse beeper limit switch	EC-100064
Horn Button	EC-001131
Horn 12V 110dB	EC-100098
Emergency Stop Switch	EC-001107
Battery Master Switch 12V	EC-100229

Operate Loader Attachments

About Loader Attachments

Your Kanga Loader becomes a powerful, job specific work tool with the addition of attachments. Attachments are available for civil, arbour, agricultural, landscaping, road maintenance, earthmoving, fencing, contracting, irrigation and other applications.

Safety Guidelines for Attachments

In addition to the general safety practices related to the operation of your Kanga Loader, you must follow the safety guidelines given for the attachment you are using. Before commencing work with any attachment, ensure that all tasks and risks associated with the activity have been identified and appropriate risk mitigation measures have been put in place. Attach the hose bracket (if any) to loader arm. This will keep them secure and away from entanglement with loader arms, cylinders, and other parts.

WARNING

Only Kanga-designed and approved attachments are to be used in conjunction with your Kanga Loader. No other attachment is to be used until the design and use of the attachment has been assessed and authorized by Kanga.

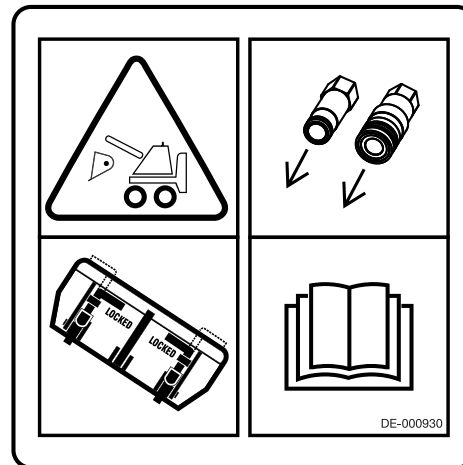

WARNING

Before use, always read the operator's manual and ensure the attachment is securely attached to the machine. Locking pins must be engaged and hydraulic hoses connected.

Hydraulic Attachment Connections

Kanga Loaders are fitted with hydraulic Quick Release Couplings (QRC) to connect the different attachments. The QRCs are paired as male and female to ensure correct hose connections.

HYDRAULIC FITTING	PART NUMBER
3/8' Male QRC	HC-100285
Male QRC Cover	HS-100287
3/8' Female QRC	HC-100286
Female QRC Cover	HS-100288

NOTE

The *Quick Release Couplings (QRC)* can be fitted with dust caps to prevent contaminants and dust from entering the hydraulic system. Ensure the Quick Release Couplings are clean before connecting hydraulic lines.

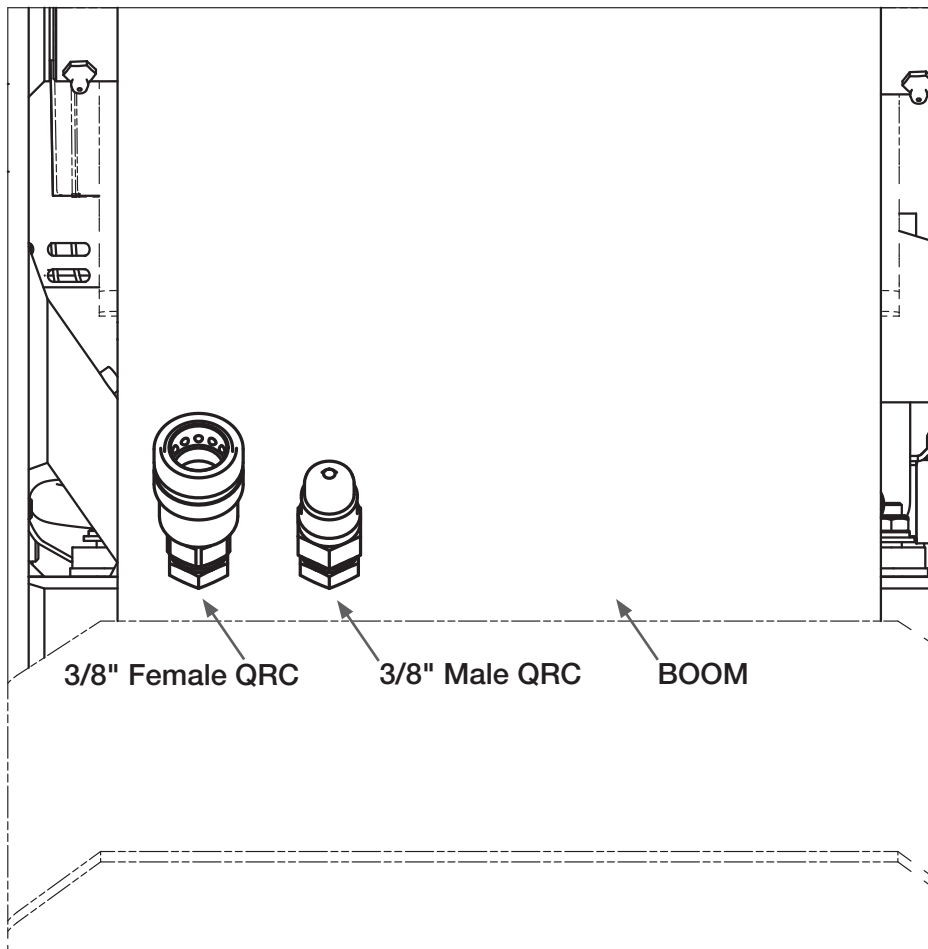

4-in-1 Attachment

Using the 4-in-1 Bucket

Connect to Male and Female couplers.

When collecting product from a heap or pile, lower the arms all the way down until the arms touch the bump stop. Then using your tilt lever roll forward until the bucket is level with the ground. Drive the bucket into the pile or heap. As the loader comes to a stop, hold the drive levers forward and gently roll the bucket back using the tilt lever towards the operator. This process will make sure you have a full load in your bucket. Using the tilt instead of raising will decrease resistance and have more break out force than trying to lift product out of the pile or heap.

WARNING

When transporting material in the bucket on slopes or rough ground, always keep the bucket close to the ground. This lowers the loader's centre of gravity to maximize stability.

When scraping, levelling, and surface stripping, lower the bucket to the ground and tilt it down.

Drive forward. The bucket will bite into the soil as you move forward.

CAUTION

Do not step off the operator platform with the load raised or the machine moving.

CAUTION

Always ensure that the attachment locking pins are fully engaged at all times.

Important Safety Guidelines

Always attach, change or remove a bucket on flat even ground. Loader operations involve rapid movement and unpredictable direction changes. Because of this, the working area must be kept clear of bystanders and any personnel other than the operator. To avoid accidents, the operator must be vigilant at all times.

Establish and maintain a minimum 4-meter (12-feet) exclusion zone around the working area. No person other than the operator should enter the work zone while the machine's engine is running.

Observe all underground utility markings carefully. Maintain a no-work zone 2 meters (6 feet) from any utility marking.

Do not carry passengers, either on the machine or an attachment.

DANGER

Do not place an object or body part between the jaws of an open bucket or under the bucket for any reason.

Power Head and Auger Attachments

Fitting the Power Head

Drive the loader to the attachment. Couple the attachment plate onto the attachment. Raise the power head slightly and fully engage the locking pins. Turn the engine off and push the AUX lever forward and backward to release any hydraulic line pressure. Clean the hydraulic fittings (QRCs) and connect them to connections A and B. See "Hydraulic Attachment Connections" on page 38.

To remove, reverse the order given above. To prohibit dirt from entering the hydraulic system, always reconnect the attachment hoses into one another or fit with supplied dust caps.

Fitting the Auger

Once fitted to the loader, raise the power head high enough to allow the auger to be positioned into the power head's square drive shaft. Drive the power head forward, positioning the drive into the auger and aligning the locking pin holes.

CAUTION

Large auger fitting is a two-person operation.

Operating Instructions

Complete a pre-operation check. Insert the locking pins and lock in place. Ensure that the power head is securely attached to the loader. Check that the couplings are engaged and check for leaks. Tighten and repair as required. Check that bolts securing the pilot are tight. Inspect the cutting tips and teeth. Ensure that they are in good condition and firmly attached.

NOTE

Teeth should display slight movement.

Start the auger turning in a clockwise direction by activating the AUX lever downward towards the operator. Lower the auger by pushing the arm lever forward. If the ground is hard, the front wheels of the loader will lift off the ground. *Note:* The front wheels should never come off the ground more than 1 inch (25mm).

As the auger cuts into the ground, the arm travel arc will move the auger out of vertical. To keep the auger vertical, move the loader backward or forward slightly to compensate. Continually clear the hole during digging by pulling back on the arm lever to raise the auger.

If the auger stops rotating, push the auxiliary forward to disengage hydraulic flow to the power head. Push further forward and hold the auxiliary lever to put the power head in reverse. This may dislodge the auger, allowing it to be raised. If the auger does not dislodge then push forward on the auxiliary lever and pull back on the tilt lever to pull out the auger while rotating. Drill a trial hole in a clear area away from utility markings to practice operations and become familiar with the procedure.

When transporting the auger drive to the desired location the arms should never be raised in the air. The arms should be against the chassis in the bump stop position and the power head should be in the locked position. Then fully rolled back towards the operator using the tilt lever.

CAUTION

Keep clear of the auger at all times (4m/12 ft minimum distance).

Important Safety Guidelines

Establish and maintain a minimum 4-meter (12-feet) exclusion zone around the working area. No person other than the operator should enter the work zone while the machine's engine is running.

Observe all underground utility markings carefully. Maintain a no-work zone 2 meters (6 feet) from any utility marking.

DANGER

Do not place hands, feet, or other body part or object under the auger attachment for any reason.

Trencher Attachment

Fitting a Trencher

Drive the loader to the attachment. Couple the attachment plate onto the attachment. Raise the trencher slightly and fully engage the locking pins. Turn the engine off and push the AUX lever forward and backward to release any hydraulic line pressure. Clean the hydraulic fittings (QRCs) and connect them to connections A and C. See "Hydraulic Attachment Connections" on page 38.

To remove, reverse the order given above. To prohibit dirt from entering the hydraulic system, always reconnect the attachment hoses into one another or fit with supplied dust caps.

Operating Instructions

Complete a pre-operation check. Ensure that the trencher is securely attached to the loader. Check that the couplings are engaged and check all joints for leaks. Tighten and repair as required. Inspect the cutting teeth, ensuring that they are in good condition and firmly attached.

Tension the chain. Correct tension requires about 35–45mm (1.5 inches) of lift. To adjust the chain to this specification, loosen the 16mm bolt, adjust the adjustment wedge and re-tighten the bolt.

Position the trencher and activate the AUX lever so that the chain runs along the top of the boom and returns back toward the operator on the underside. Engage the TILT lever so that the boom and chain arcs down to dig a trench. When the desired depth is achieved, slowly drive the loader backward along the trench line.

Trencher Attachment Control

On the Kanga 2 Series Loader, the Trencher attachment speed is controlled by the engine revs.

On low engine revs and with the attachment off the ground, engage the AUX lever by moving it toward the operator.

Increase the revs to desired level.

Lower the attachment to working position.

Pull the drive levers all the way back.

NOTE

Minor adjustments are required to maintain a straight line, as the loader will tend to "drift" to the left.

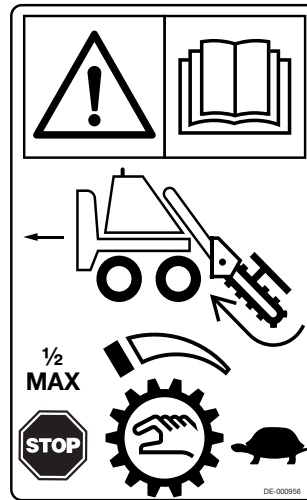

Important Safety Guidelines

Establish and maintain a minimum 4-meter (12-feet) exclusion zone around the working area. No person other than the operator should enter the work zone while the machine's engine is running.

DANGER

Visit the respective "Before You Dig" authority website for your Country or State, several days before work will commence to have the work area marked for underground utilities. Do not begin work until all markings are in place.

DANGER

Do not place hands, feet, or other body part or object under the trencher for any reason.

Observe all underground utility markings carefully. Maintain a no-work zone 2 meters (6 feet) from any utility marking.

NOTE

"Before You Dig" website is a service available in the Australian region and is used to receive asset plans. The asset plans are utilised to ensure underground services are located and marked before work commences. To prevent damage to utilities infrastructure. Find a similar service in your region before you dig.

Bucket Broom Attachment

Fitting the Bucket Broom

Connect the attachment plate of the loader to the bucket broom frame. Check to confirm that the quick hitch attachment locking pins are engaged. Turn the engine off and push the AUX lever forward and backward to release any hydraulic line pressure. Clean the hydraulic fittings (QRCs) and connect bucket broom hoses to connections A and C. See "Hydraulic Attachment Connections" on page 38.

To remove, reverse the order given above. To prohibit dirt from entering the hydraulic system, always reconnect the attachment hoses into one another or fit with supplied dust caps.

Operating Instructions

Complete a pre-operation check. Ensure that the bucket broom is securely attached to the loader. Check that the couplings are engaged and check all joints for leaks. Tighten and repair as required.

Place the AUX lever in neutral. Start the engine and adjust the engine RPM lever to suit the operation power you require. Position the bucket broom flat on the ground. Engage the AUX lever, pulling toward the operator. The broom will begin rotating and sweeping into the bucket base.

Bucket Broom Attachment Control

On the Kanga 2 Series Loader, the Bucket Broom attachment speed is controlled by the engine revs.

On low engine revs and with the attachment off the ground engage the AUX lever by moving it away from the operator.

This will rotate the brush counter clockwise for forward movement. (When viewed on the RHS of the attachment.)

Increase the revs to desired level.

Lower the attachment to working position.

Push drive levers all the way forward.

To Switch Direction

If sweeping in a reverse direction, then pull the auxiliary lever toward the operator. This will allow

the brush to rotate in a clockwise direction. (When viewed on the RHS of the attachment).

NOTE

The bucket should only be pushed forward with the loader drive system.

To empty debris from the bucket, disengage the AUX lever and tilt the bucket back slightly. Travel to the dumping location, then raise the lift arm with Lever 1 and tilt the bucket forward to dump the debris out using Lever 5 (see "Control Levers" on page 27).

Important Safety Guidelines

Establish and maintain a minimum 4-meter (12-feet) exclusion zone around the working area. No person other than the operator should enter the work zone while the machine's engine is running.

Observe all underground utility markings carefully. Maintain a no-work zone 2 meters (6 feet) from any utility marking.



CAUTION

Minimum Personal Protective Equipment required. Wear respiratory and eye protection while using the bucket broom.



DANGER

Do not place hands, feet, or other body part or object under the trencher for any reason.

NOTE

Connect the bucket broom hoses to connections A and B. Control the speed by gently engaging both drive levers forward. The further forward the levers are pressed, the faster the machine travels. Allowing the levers to gently return to centre will slow the machine's travels. Allowing the levers to gently return to centre will slow the machine's travel.

Rotary Hoe Attachment

Fitting the Rotary Hoe

Connect the attachment plate of the loader to the rotary hoe frame. Check to confirm that the quick hitch attachment locking pins are engaged. Turn the engine off and push the AUX lever forward and backward to release any hydraulic line pressure. Clean the hydraulic fittings (QRCs) and connect rotary hoe hoses to connections A and C. See "Hydraulic Attachment Connections" on page 38. Connect the hose bracket to the machine and secure the R-clip.

To remove, reverse the order given above. To prohibit dirt from entering the hydraulic system, always reconnect the attachment hoses into one another or fit with supplied dust caps.

Operating Instructions

Complete a pre-operation check. Confirm that the rotary hoe is securely attached to the loader and the couplings are engaged. Check all joints for leaks. Tighten and repair as required. Check that the rotary hoe and cutting blades are in good condition.

Place the AUX lever in neutral. Start the engine and adjust the engine RPM lever to suit the operation power you require. Position the rotary hoe flat on the ground. Engage the AUX lever, pushing away from the operator. The hoe blades will begin rotating counter-clockwise when viewed on the RHS of the attachment.

Rotary Hoe Attachment Control

On the Kanga 2 Series Loader, the Rotary Hoe attachment speed is controlled by the engine revs.

On low engine revs and with the attachment off the ground engage the AUX lever.

Check to ensure that the Rotary Hoe blade is rotating counter-clockwise when viewed on the RHS of the attachment.

Increase the revs to desired level.

Lower the attachment to working position.

Pull drive levers all the way back.

NOTE

The rotary hoe should only be pulled in reverse with the loader drive system. Do not push the rotary hoe.

Using the drive levers, drive the machine. Control speed by gently engaging both levers rearward. The further rearward the levers are pressed, the faster the machine travels. Allowing the levers to gently return to centre will slow the machine's travel.

Adjust the travel speed of the loader to achieve the required condition of the soil. For example, slower travel speed will turn the soil over more, resulting in softer soil, and faster speed will turn the soil over less, resulting in a chunkier soil texture.

Important Safety Guidelines

Establish and maintain a minimum 4-meter (12-feet) exclusion zone around the working area. No person other than the operator should enter the work zone while the machine's engine is running.

Observe all underground utility markings carefully. Maintain a no-work zone 2 meters (6 feet) from any utility marking.

DANGER

Never carry out maintenance of any type on the rotary hoe while it is attached to the loader or other power source.

DANGER

Do not place hands, feet, or other body part or object near or under the rotary hoe for any reason.

NOTE

Connect the Rotary Hoe hoses to the Quick Release Coupling connections as shown on "Hydraulic Attachment Connections" on page 38 .

Control the speed by gently engaging both drive levers and pushing them backward.

Fork Tyne Attachment

Important Safety Guidelines

Establish and maintain a minimum 4-meter (12-foot) exclusion zone around the working area. No person other than the operator should enter the work zone while the machine's engine is running.

During loader operation, maintain a minimum "no-work zone" buffer of 3 meters (10 feet) from any overhead electrical service and 2 meters (6 feet) from any underground service.

Do not carry passengers, either on the machine or on the fork tynes.

Do not travel with the tynes raised, especially when carrying loads.

Avoid overloading the loader or the fork tynes. Refer to the fork tyne manual for specific Rated Operating Capacity (ROC).

DANGER

Do not place hands, feet, or other body part or object under the forks for any reason.

Angled Backfill Blade Attachment

Important Safety Guidelines

Connect to 4 in 1 bucket circuit (Blue + White).

Establish and maintain a minimum 4-meter (12-foot) exclusion zone around the working area. No person other than the operator should enter the work zone while the machine's engine is running.

Observe all underground utility markings carefully. Maintain a no-work zone 2 meters (6 feet) from any utility marking.

Do not carry passengers on the machine or on attachment.

Do not travel with attachment raised.

DANGER

Do not place hands, feet, or other body part or object under or near the angled backfill blade for any reason.

Install Track

Preparation

1. A suitable crane is needed to lift the loader onto a stable and safe work stand.
2. Deflate tyre pressures to 15 psi (103 kPa).
3. Remove the wheel nuts and use a suitable lever to remove the front wheel from the hub. Repeat for the rear wheel.

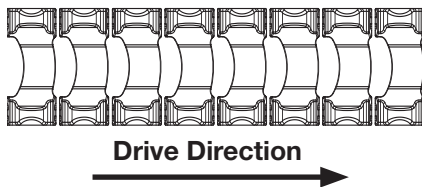

4. Lay the wheels flat on the floor. Ensure that the correct rotational direction of the track is observed.
5. Position the wheels into the track and ensure the wheel stud holes align with the studs orientations on the hubs . This will assist with aligning the wheels to the studs during assembly.

CAUTION

Keep clear of moving parts and pinch points at all times while installing the tracks, finger and hand injuries could occur.

6. Install the scissor jack assembly between the two tyres and finger tighten the scissor jack until the nesting plates contact the tyres and can hold itself in place without falling out.

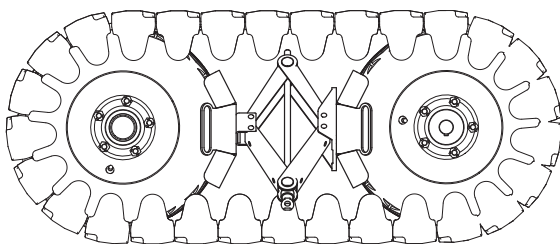

CAUTION

For safety, it is recommended that maintenance is carried out in a workshop environment, using the correct tooling and equipment for the task. Please contact Kanga Loaders for service and maintenance information, if needed.

Installation

7. Working with another person ,lift the front wheel (with track and installation scissor jack tool) onto the front hub and install wheel nuts.
8. Lift the rear wheel and proceed to fit the rear wheel to the hub. If fitment is not possible , use the crank handle to tension the scissor jack until the alignment matches. If the studs don't align ,rotate the rear hub using an adjustable wrench while partially depressing the forward/reverse control lever. **DO NOT START THE ENGINE !**

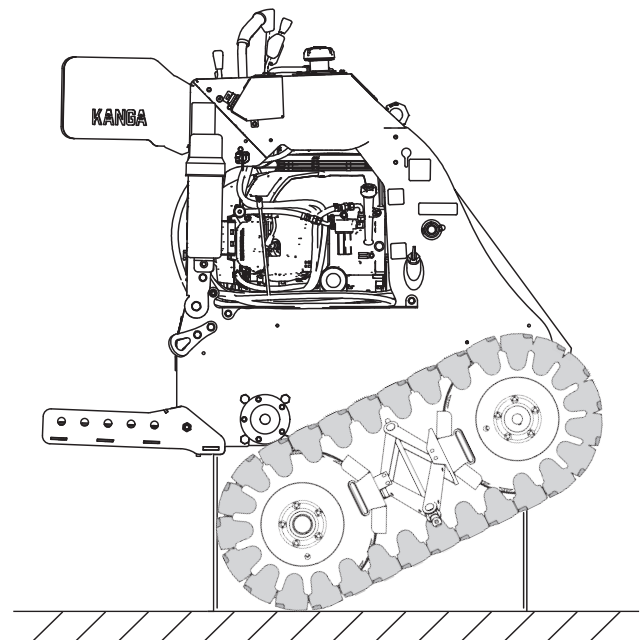

9. Install the rear wheel nuts.

NOTE

If the tracks cannot be extended far enough using the scissor jack, reducing the tyre pressures down further to 10 PSI. This will allow the scissor jack to extend further or partially depress the forward/reverse control lever may also help.

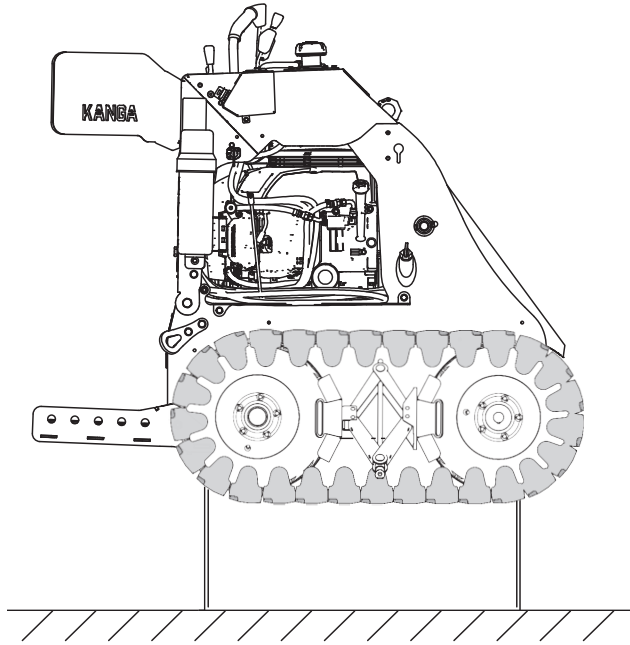

10. Remove the scissor jack assembly.
11. Tighten all wheel nuts to 135 Nm (100 ft-lbs).
12. Re-inflate tyres to between 55 psi (379 kPa) and 75 psi (517 kPa).
13. Repeat the process for the other track.
14. Use a crane to lift the loader and place it on the ground.

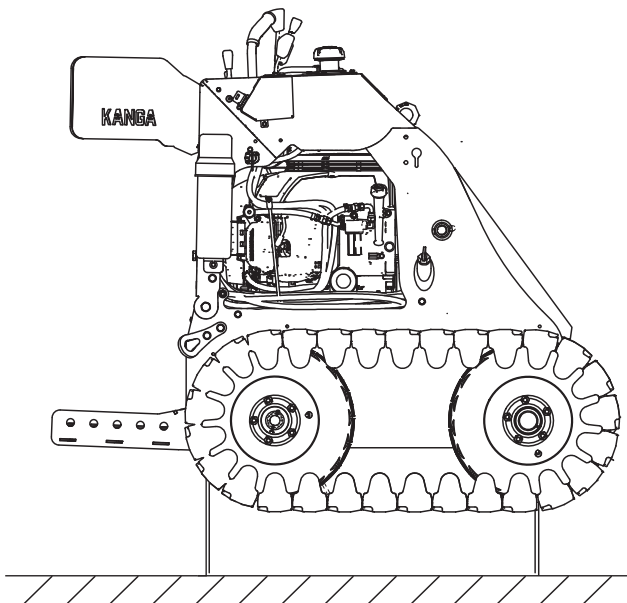

Final Check

- Tracks installed.
- All Wheel Nuts are torqued to spec.
- All Tyres are Inflated to between 55 to 75 psi.
- All tools are removed from the area.
- Loader is ready to be lowered off of the platform.

REPLACEMENT PARTS	
Description	Part Number
Track Tool	Z-007400

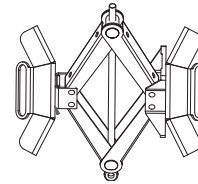

Track Tool

Track Orientation

URO Track Grip Option

For grip, the track can be set to two different configurations. All loaders are delivered with the configuration that is well-suited for a variety of working conditions. The second configuration (Option 2, right) is best for muddy or sandy conditions.

Changing the Track Option

To change the track option, begin by removing the tracks from the machine, following the steps in the track removal section.

1. Once the track is removed, lay the track on its side. Use a flat-blade screwdriver or other suitable lever to move the chain through the track to the joining link (H).

NOTE

If you have trouble doing this, you can purchase a spare joiner for repair or adjustment (Part Number L117700).

1. Once you have found the joining link, insert two 6mm bolts (or other suitable pins) to hold the chain while you remove the joiner link (I).
2. Pull out the locking bolts and remove the chain by pulling it through the track segments. Turn the track and repeat steps 1 to 3 on the other side (J).
3. Lay segments out on the floor in the required pattern. Feed the chain in from one end to the other (K).
4. Once the chain is fed all the way through, install the 6mm locking pin in one end of the chain and push up all the segments tightly. Insert the 6mm locking pin through the other end. Repeat steps 4 and 5 with the chain on the other side (L).
5. Once both chains are pulled through and secured with pins, lay the track on its side. Place the securing pins through the link.

NOTE

Ensure that the holes through which you will fit the joining link are exposed (M).

OPTION 1—STANDARD (SINGLE DIRECTION)

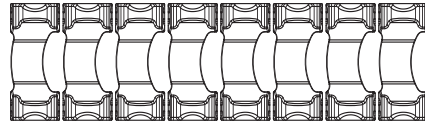

OPTION 2

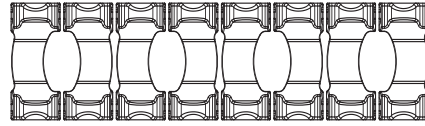

H

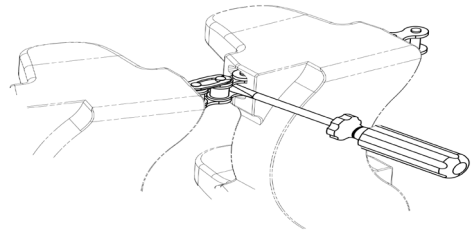

I

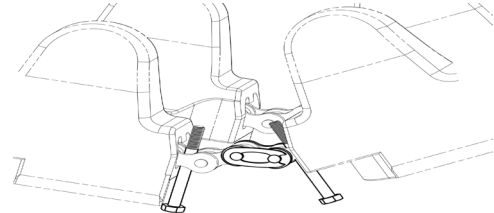

J

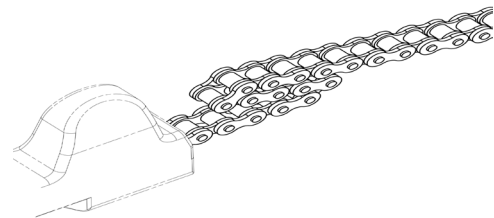

K

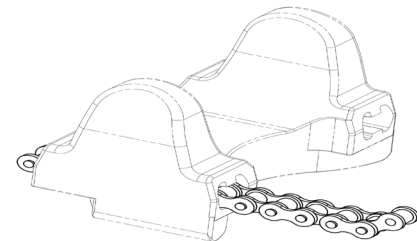

NOTE

Cleaning the chain will assist in the process of pulling the chain through. Wash it clean, then soak in diesel. If you have trouble feeding the chain through, thread in a piece of 3mm wire from the opposite end, connect it to the chain, and gently pull the chain through.

- With the track on its side, install the joining link from inside to outside. The spring clip is on the outside. Flip the track over and repeat on the other side. Remove the locking bolts (or pins, if used) and the track is now ready to install. Refer to track installation instructions.

Track Link Removal

If traction between the drive wheel and track is lost, increase tyre pressure in 5 PSI (34 KPA) stages to compensate for wear. If traction is lost when the tyre pressure is set at 75 PSI (517 KPA), you must tighten the tracks by removing track chain links. The following steps describe track link removal.

- Follow the track removal instructions to remove tracks.
- Once track is removed, lay the track on its side.
- Choose a spot on the track. Pry the left-hand segment apart to allow the insertion of a 6mm locking bolt through the chain link. Next, pry the right-hand segment back as far as you can with a screwdriver to expose two full side plates (four pins).
- Use a chain splitter or angle grinder to grind off two pins on the outside of the four pins. This action will remove one link. Use a pin punch to drive the pins out to release the chain section. (N)
- Turn the track over and perform the same steps on the other side, releasing the track so it is no longer joined.

Use joiner link (Part Number L117700) to rejoin the chain. You have now shortened the chain by one link. Turn track over and perform the same steps on the other side.

- Remove the 6mm locking bolts on both sides, and reinstall the tracks.

NOTE

Once links are removed, tyre pressure must be decreased to normal levels.

L

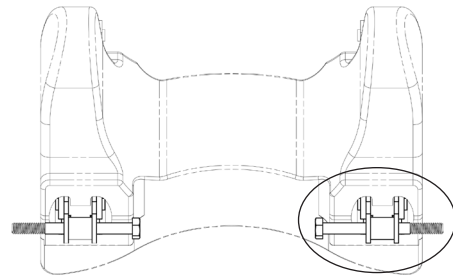

M

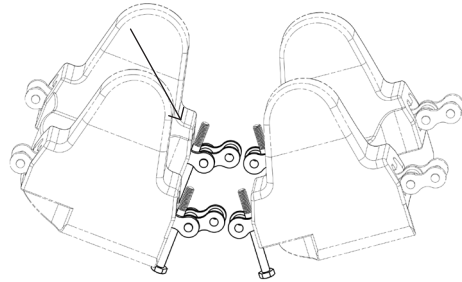

N

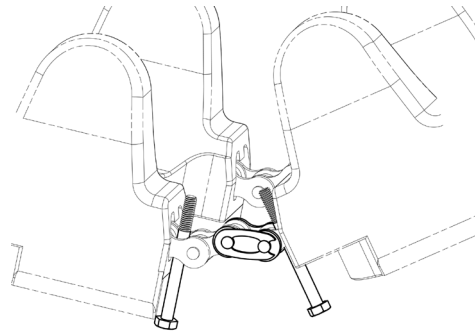

REPLACEMENT PARTS	
Description	Part Number
URO Track Roller Train (1 per side)	DK-003254
Chain joiner link	L-117700

Kanga Handover Worksheets

The following 3 pages are to be filled out as part of the machine handover with the centre spread removed by the Kanga Loaders representative.

The information will be stored by Kanga Loaders for warranty and after sales service.

Please note: The centre 4 pages do not form part of the owners operators manual.

TO BE FILLED OUT BY KANGA LOADERS MANUFACTURING

Record the Main Component Serial Numbers

2 Series			
WHEELED <input type="checkbox"/>		<input type="checkbox"/> TRACKED	
Kanga Serial Number			
Engine Type / Power	<input type="checkbox"/> Honda GXV630 - Petrol - 20HP		
Engine Serial Number			
Kanga Model	PW220 <input type="checkbox"/> PT220 <input type="checkbox"/>		
Wheel Motors		REAR RIGHT BATCH# & SERIAL#	8048 SN:
		REAR LEFT BATCH# & SERIAL#	8010 SN:
Lift Ram	NORDON 2.5" x 1.25" x 6" Stroke	PART # CY-000163	
Tilt Ram	NORDON 2" x 1" x 4" Stroke	PART # CY-000147	
Hydraulic Pump Displacement	8.3 cc/rev.	PART # HA-101147	
Control Valve	SALAMI 5 BANK	PART # DL-004711	
Purchase Date			

Loader Checklist

MODEL: PW220 PT220

SERIAL NUMBER:

ENGINE NUMBER:

INSPECTOR'S NAME:

MACHINE BUILT BY:

DATE:

VISUAL CHECK	✓	✗
1. Damage		
2. Loose bolts/nuts		
3. Rust		
4. Leakage oil - Engine or Hydraulic		
5. Wiring		
6. Paint work		
7. Any untidy weld spots or runs		
8. Check of fittings alignment		
9. Is loader clean and free of debris?		
10. Are pipes and hoses clear of parts on loader?		
SERVICE		
1. Tie down lugs fitted on body		
2. Correct attachment plate/operation OK with test jig	✓	✗
3. Lubricate loader, grease all linkages		
4. All pins and bushes fitted and tight		
5. Wheel nuts tensioned to 135 Nm (100 ft-lb)		
6. Is the track slot forward and tyre direction correct?		
7. Is the tyre pressure to specification?		
8. Air element and hose clearance and connections tight		
9. Sediment in fuel filter/tank (drain fuel tank)		
10. Is engine EPA compliant and label fitted?		
11. Is engine rotation direction correct? (Clockwise direction viewed from top)		
12. Are QRCs correctly aligned and covers fitted?		
13. Spare key in compendium		
14. Battery is secure and boot is on alternator		
15. Is the splash plate fitted?		
16. Ensure control knobs are not split and are secured		

NOTE:
Where optional parts are Not Fitted or Not Applicable (N/A).
Insert a Dash: —

OPERATIONAL CHECK	✓	✗
1. Gauges/switches and connections/dash lights		
2. Attachment plate		
3. Throttle lever (not too tight or loose)		
4. Levers and linkages working correctly		
5. Unusual noises or vibrations.		
6. Petrol (Gasoline) engine idle 1350-1450 RPM		
7. Petrol (Gasoline) engine max 3550-3650 RPM		
8. Is loader easy to start?		
9. Is hour meter working? Test time = hrs.		
10. Check that lift cylinder stops in correct position and locked		
11. Aux stop cable: Cable length is correct; tested 5 times		
GUIDANCE	✓	✗
1. Correct stickers applied for country/export		
2. Correct tire pressure sticker attached		
3. Identification plate (correct number stamped)		
4. Operator's Manual present		
5. Engine Manual (Honda or Kubota warranty form) present		
FLUID COMPARTMENT CHECK	✓	✗
1. Battery condition		
2. Engine oil level		
3. Hydraulic oil level		
4. Inspect fuel tanks for leaks		
5. Hydraulic filter housing directions and elements tight		
OTHER	✓	✗
1. Is the "Passed By" sticker attached and signed?		
2. Check machine to be shipped against order		
3. Is the loader ready for delivery?		
4. Have back protection bars been ordered and fitted?		
5. Lights/beacon operational (where fitted)		
6. Horn/reverse beeper operational (where fitted)		
7. Track tool attached to loader		

Received the above loader, attachments, and documentation as stated above in good condition. The correct operation of the loader has been explained to our satisfaction. We understand that this loader should be operated by a properly trained operator. We are aware that the use of this loader in any manner or place for which it is not designed will render it unsafe.

DISTRIBUTOR'S NAME:

INSPECTOR'S SIGNATURE:

Delivery Sheet & Warranty Registration

Owner Name		Date
Owner Street Address		
Owner City, State, Post Code / ZIP		
Owner Email		Owner Telephone
Dealer/Delivered by		
Products		Serial Number
(1)		
(2)		
(3)		
(4)		
(5)		

	Salesperson	Owner
Customer's Name _____	Initials	Initials
Accept delivery of the equipment as detailed above. All equipment has been inspected and is accepted.		
Have had the operational and safety procedures explained to me for the loader and attachments and have been provided a copy of these procedures for reference and use.		
Have received a copy and understand the Operator's Manual and safety information contained therein for all equipment and attachments supplied.		
Owner: I understand that I am required to perform a risk assessment covering all tasks before I operate this machine and/or any attachment.		
Understand the warranty conditions and maintenance requirements for the loader and attachments.		

Comments

PURCHASER'S SIGNATURE _____ DATE _____

Maintain Your Kanga Loader

Inspection and Checks

Before operating the Kanga Loader each day, the operator must complete the inspection and checks as outlined on the following pages. This inspection will ensure the equipment is in safe working order and aid in the detection of malfunctions between scheduled maintenance checks.

CAUTION

While it may not be the operator's responsibility to perform mechanical maintenance, he or she should be thoroughly familiar with the loader. Such familiarity is critical to operator safety.

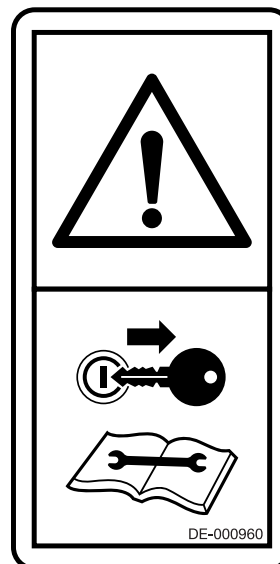

DANGER

In addition to ensuring safety, the daily inspection can prevent many costly maintenance jobs. Should an issue arise, however, consult an authorized Kanga technician.

CAUTION

Before any maintenance is performed, switch engine off and remove the key. Never leave the key in an unattended machine.

The owner should retain evidence that proper maintenance has been performed as prescribed. A claim against a warranty will not qualify if it results not from defective material or authorized workmanship, but from a lack of maintenance.

Never operate a Kanga Loader that is known to be damaged or malfunctioning. Remove the key from the ignition and tag out the machine using an "Out of Service" tag. Contact your Kanga service technician.

Defective components, equipment malfunctions, or both can jeopardise the safety of the operator and other personnel while also causing extensive damage to your loader. Remember: A poorly maintained loader can be a significant operational hazard.

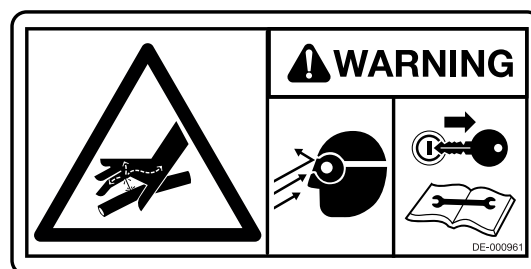

WARNING

This machine operates on high hydraulic fluid pressure. Always wear eye protection when operating or performing maintenance on this machine. See "Hydraulic Attachment Connections" on page 38 on safe connection and disconnection of attachments for hydraulic safety.

Daily Checklist

LOADER				
Element		Yes	No	Comment
Wheels	Good condition, with adequate tread			
	Adequate pressure			
	Wheel nuts secure			
Guarding	Good condition			
	Secure			
Hydraulics	Good condition of hoses (check for leaks)			
	Good condition of casings (check for leaks)			
	Good condition of rams (check for leaks)			
	Adequate hydraulic oil level			
Controls	Correct operation			
	Responsiveness			
Structure	Adequate weld condition			
	Free of cracks or damage			
	Linkage pins greased			
Bolts and fasteners	Check pivot pins for wear or damage			
	Tight			
	None missing or damaged			
Battery	Terminals tight			
	Free of corrosion			
	Good condition (check indicator)			
Safety decals	Legible			
	All in place			
Engine	Adequate crankcase oil level			
	Check air cleaner/filter			
Air Management	Empty pre-filter cleaner bowl (if fitted)			
	Clean air filter			

Daily Checklist (continued)

Element		Yes	No	Comment
Fuel	No leakage			
	Adequate fuel level			
Operator's Manual	Present with machine			

ATTACHMENT(S)				
Element		Yes	No	Comment
Guarding	Good condition			
	Secure			
Hydraulics	Good condition of hoses (check for leaks)			
	Good condition of casings (check for leaks)			
	Good condition of rams (check for leaks)			
Controls	Correct operation			
	Responsiveness			
Structure	Adequate weld condition			
	Free of cracks or damage			
Bolts and fasteners	Tight			
	None missing			
	Attachment locking pins in place			
Decals	Legible			
	All in place			
Operating supplement	Present with machine/attachment			

Loader Arm Maintenance

Important Safety Guidelines

DANGER

Attachments must be removed before working on the loader arms. Maintenance must be performed on a flat and even surface.

DANGER

When performing maintenance activities on the loader arm, particularly when working with the arm in the raised position, you must carefully follow all safety guidelines.

Always secure the arm using the supplied arm lock.

Ensure the working area is kept clean. The area must be free of oil, grease, and debris. Keep a fire extinguisher on hand during maintenance operations.

Mark the maintenance work area using cones or barricades.

The arm lock must always be used to physically hold the boom in the raised position.

Do not attempt to lower the boom with the arm locking device in place.

Remove attachment before working on loader arms

DANGER

Never rely solely on machine hydraulics to keep the arm in the elevated position during maintenance.

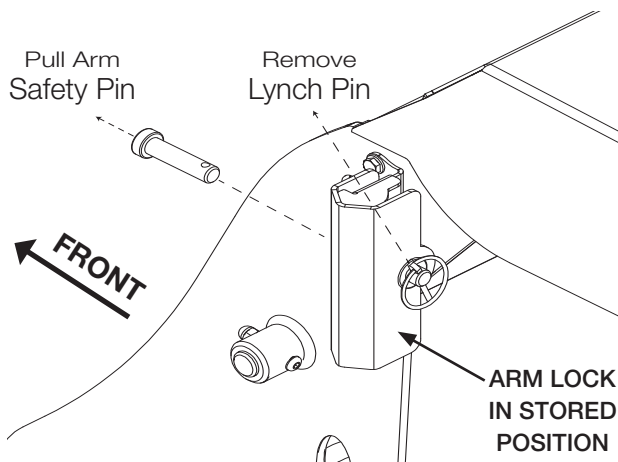

DANGER

The loader arm poses a whole body crushing hazard. Ensure that the arm lock retaining device is correctly installed whenever the arm is raised for maintenance.

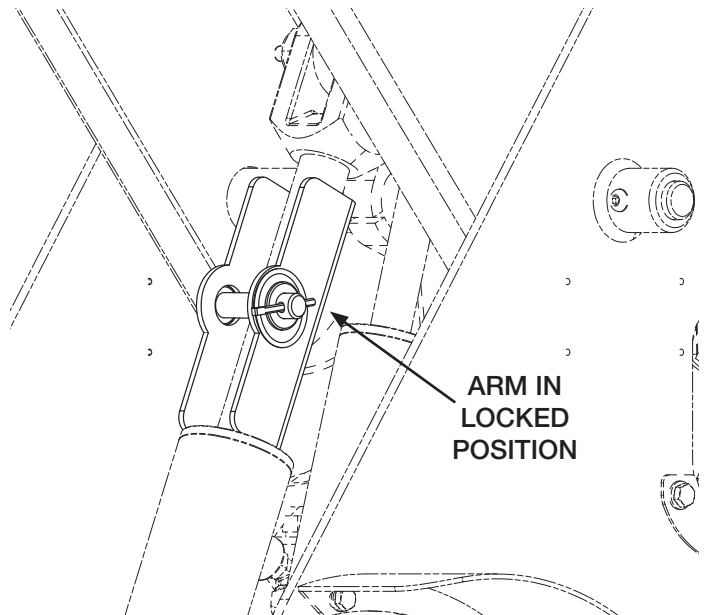

REPLACEMENT PARTS	
Description	Part Number
Arm Safety Pin Replacement	PI-000314
Rubber Safety Pin Grommet	DL-004496
Lynch Pin	PI-000018

Long-Term Loader Storage

If your Kanga loader must be stored for an extended period of time, follow these guidelines for preparation and storage.

Preparation

- Complete the following maintenance prior to storage:
- Thoroughly clean the loader, including the engine compartment.
- Touch up the paint to prevent rusting.
- Replace worn or damaged parts.
- Lubricate the loader and grease any exposed cylinder rods.
- Replace all fluids and filters.
- Add fuel stabilizer to the fuel tank and operate the engine for several minutes to fully circulate the stabilizer. Move the fuel shut-off valve to OFF position. See "Shutting Down" on page 32.
- Remove the battery, check its electrolyte levels (if applicable) and ensure it is fully charged. See "Service Tasks: Battery" on page 68. Store the battery in a cool dry location where temperatures will remain above freezing.

Storage

To store, following these steps:

- Park your loader in a dry and protected location.
- Put the bucket flat on the ground.
- Place blocks under the frame to remove weight from the tyres.
- Set all controls in neutral position.
- Cover the exhaust pipe opening and any other openings that might admit small animals.
- Tag the loader to clearly indicate it is in non-operational storage condition.

Post-Storage and Return to Operation

- To return the loader to operation after a period of long-term storage, complete these steps:
- Remove cover(s) from exhaust pipe and other locations.
- Remove grease from exposed cylinder rods.
- Complete maintenance inspection and correct any issues detected.
- Lubricate the loader.
- Check tyre inflation and remove blocks under frame.
- Install a fully charged battery.
- Start the engine and operate for several minutes. Observe engine, panels, and systems for correct operation.
- Operate the loader, checking for correct function.
- Stop the engine and check for leaks. If detected, repair before returning the loader to service.

End-of-Service-Life Disposal

When your Kanga loader has reached the end of its useful life, responsible disposal of its parts, components, and fluids is required. Fortunately, much of a Kanga loader can be recycled.

NOTE

Regulations and approaches related to the disposal of materials vary from region to region. Learn more about guidelines specific to your location before proceeding with loader disposal.

CAUTION

The steps required for proper disposal may expose the dismantler to hazardous or toxic materials. Proper PPE and safety precautions are required.

The following provides general steps for proper end-of-service-life disposal:

Remove Hazardous Materials

Remove hazardous materials in an area with a sturdy, non-permeable floor.

Drain all hazardous fluids from petrol/gasoline fuel tank, oil reservoirs, and similar.

Remove the battery.

Remove items containing toxic metals, such as mercury switches and lead battery connectors.

NOTE

Each of these materials and the rags, paper, sawdust, and gloves contaminated by them must be captured in suitable containers and disposed of properly. Avoid scattering this toxic material in the environment.

Dismantle the loader

Dismantle the loader for usable or recyclable parts.

Remove all usable or recyclable parts.

Sell or store usable parts in safe, environmentally suitable ways.

Recycle remaining parts through local environmental or recycling centres.

Recycle the metal hulk.

After identifying a metal recycling vendor in your area, inquire about their requirements for preparing the metal hulk for recycling.

As required by the metal recycler, remove all plastic, synthetic fabrics, and other non-metal components.

Perform Service Tasks

About Service Tasks

The following service work should be completed by a competent service technician. Required service intervals are shown in the next section.

Determine Hours of Operation

Total hours of loader operation are displayed on the hour meter on the instrument panel.

Service Interval Indicator

When a service interval has been reached, the display will flash. Flashing ends after a two-hour operating period has passed. This is a generic setting from the gauge supplier. Please refer to "Service Intervals and Records" on page 74 for correct service intervals.

Other Instrument Panel Features

Also displayed on the instrument panel on all loaders is a charge warning light, and an oil warning light. See "Side Dash Controls" on page 28

REPLACEMENT PARTS	
Description	Part Number
Replacement Key (pair)	KS-000080
Hour Clock	DL-000877
Kid Replacement Ignition Switch	KS-000030

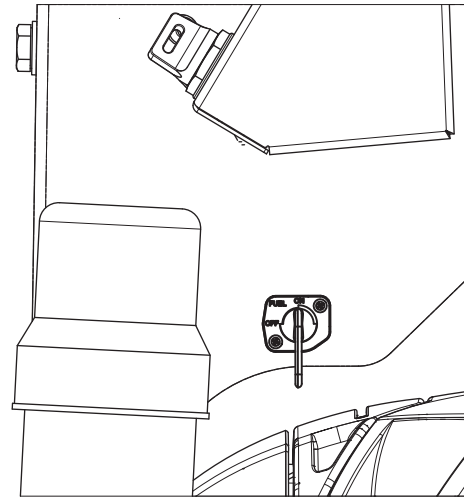

Fuel Petcock Valve

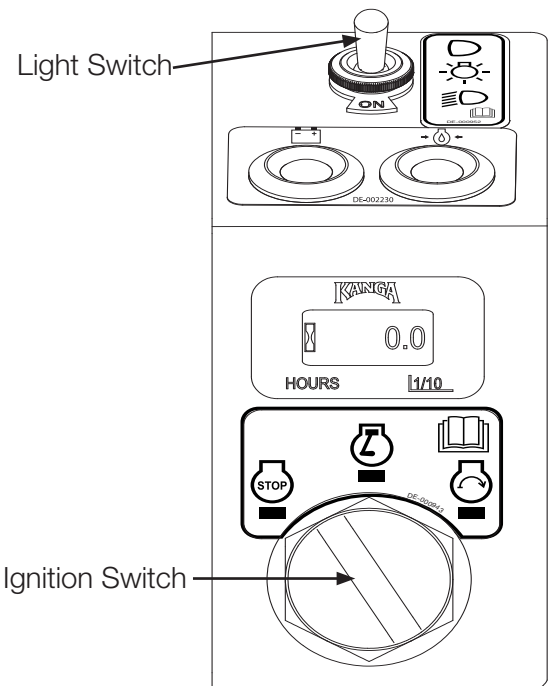

Instrument Panel showing Light Switch and Ignition Switch.

Under the Cowling

Some service tasks, such as cleaning/replacing the air filter (see "Air Cleaner" on page 59), and adjusting hydraulic settings (see "Spark Plugs" on page 59) require access to parts located under the loader's cowling.

To open the cowling:

1. Stop the loader on a flat ground, shut it down (see "Shutting Down" on page 32) and apply the parking brake (see "Parking Brake" on page 33).
2. Remove the lifting point lug (see "Lifting Your Loader" on page 26) to unlock the cowling.

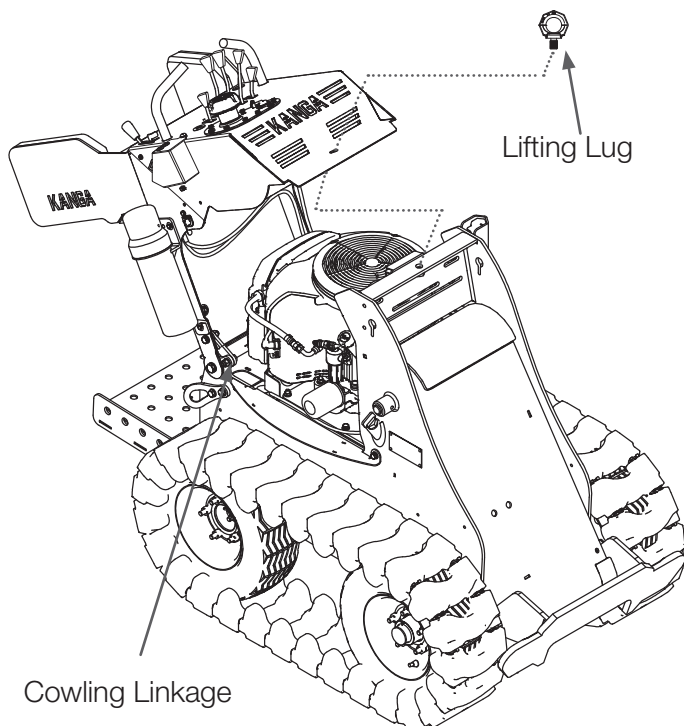

3. Tilt the cowling towards the rear of the loader by grabbing the grab handles.

Revert the operation to close the cowling. Ensure to tighten the lifting lug.

NOTE

The cowling opening angle is limited by linkages located close to the hinge point. These linkages can be released by removing the bolts to perform major services

CAUTION

Ensure the cowling is adequately supported when releasing limit linkages.

Engine Oil

Check the engine oil level daily (see "Daily Checklist" on page 50). See Honda Engine Manual for details.

Change the engine oil after the first 20 hours of operation to ensure bed in service of the engine. Thereafter, change the oil after every 100 hours.

Engine oil type SAE 10W-30 is generally recommended. See Honda Engine Manual for details.

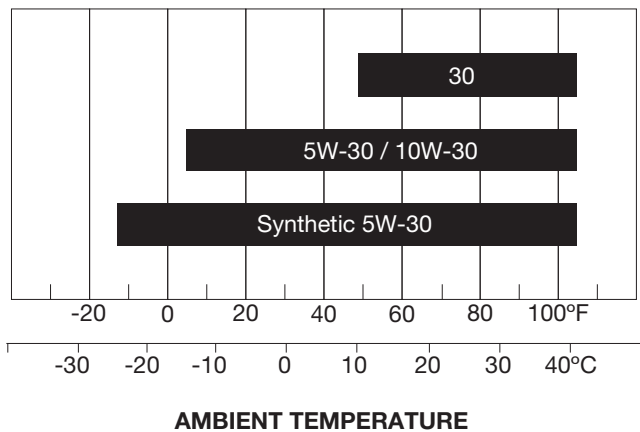

DANGER

To avoid unintended start-up during service and repairs, attach a "Do Not Operate" or similar warning tag in the driver area.

NOTE

Please contact Kanga for assistance with service and parts.

The engine oil drain line connects the engine oil sump to a fitting accessible from the front the loader (under the boom) for ease of servicing.

Release the oil drain line cutting the plastic ties which secure it. Open the oil drain line by holding the fitting firmly and undoing the drain plug using two spanners.

Reverse the operation to close the oil drain. Secure the drain line using 7.6mm (19/64 inches) cable ties.

DANGER

Secure the boom using the lock retaining device whenever performing work under the loader's arm. See "Loader Arm Maintenance" on page 52.

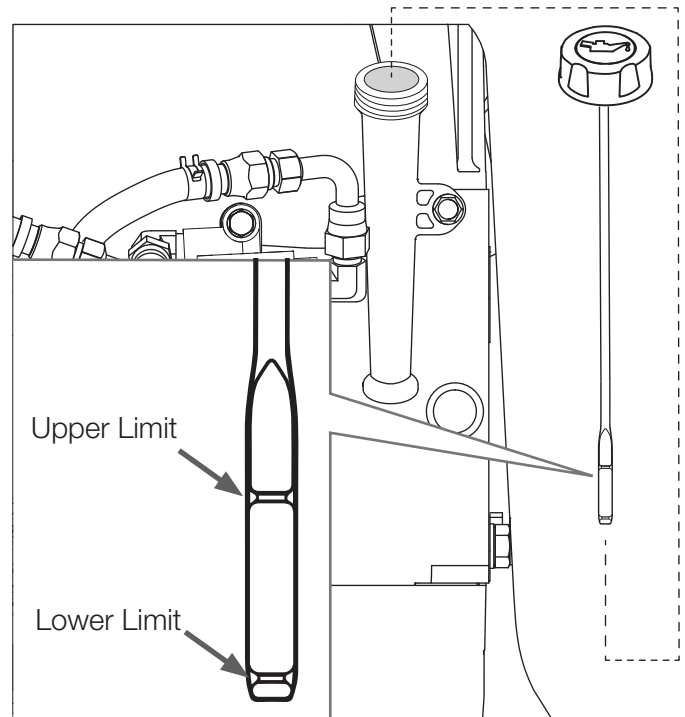
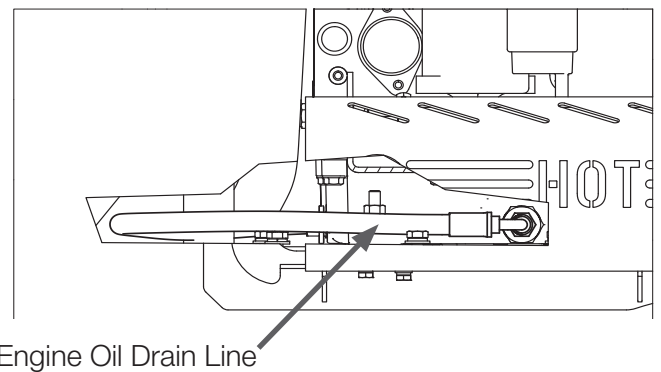
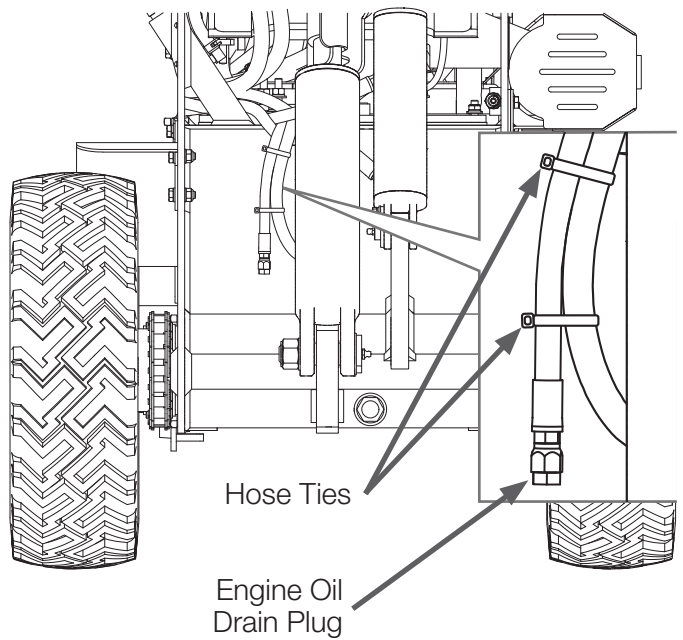

Engine oil filter

Replace the oil filter after every 100 hours of operation. See engine manual for details.

Fuel Filter

1. Make sure the engine is switched off and cool to touch.
2. Place a small catch container under the in-line fuel filter.

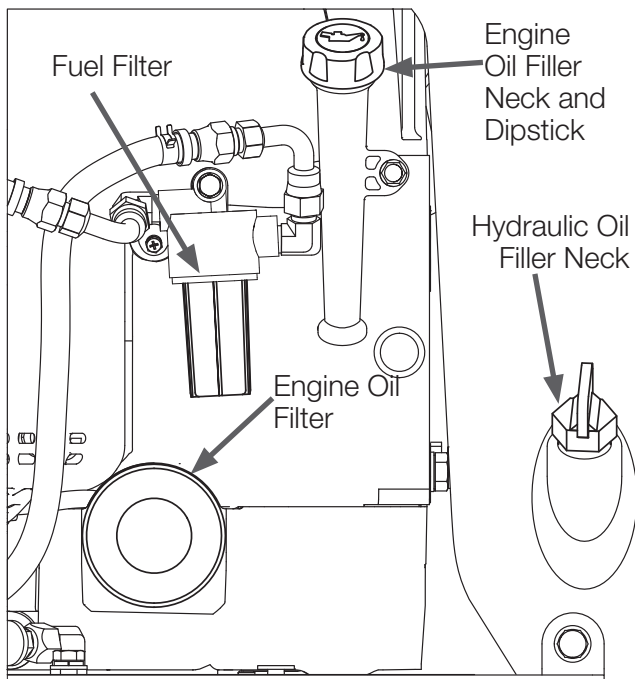

3. Close the fuel tap. Observe the flow direction of the filter before removing it.
4. Unscrew the fuel filter glass bowl carefully. Unscrew the fuel filter element.
5. Clean the fuel filter glass as required. Replace the fuel filter element.
6. Using the new seals provided, reinstall the glass bowl screwing it back in place carefully.
7. Start the engine and check for leaks. Correct, if necessary, with the engine switched off.

Idle Speed

Check engine idle speed after every 200 hours of operation. Adjust if out of specification. See Honda engine manual for details.

Valve Clearance

Check and adjust engine valve clearance after every 200 hours of operation. See Honda Engine Manual for details.

Spark Plugs

Inspect and adjust spark plug gaps every 100 hours. Replace the spark plugs every 200 hours. See the Honda engine manual for details.

Air Cleaner

Inspect and clean the engine air filter every day. Replace the air paper filter element after every 100 hours of operation, or sooner if operating in a dusty environment

To access the air cleaner you need to open the cowling (see "Under the Cowling" on page 57). Remove the air filter cover by releasing the latches on both sides of the cover.

Follow Honda Engine manual instructions to inspect, clear and/or replace air cleaner elements.

NOTE

Please contact Kanga for assistance with service and parts.

REPLACEMENT PARTS		
Description	Part Number	Qty
Fuel Filter Element	DL-001253	1
Spark Plug NGK (ZFR5F-NGK)	KS-000027	2
Air Filter Element	KS-000403	1
Air pre filter	KS-000405	1

Service Tasks: Hydraulics

Hydraulics

Perform the following work after every 100 operating hours:

With arms down and oil cold, check hydraulic fluid level. The hydraulic oil should be at level FC (see hydraulic oil dipstick figure) when the oil is cold and all rams in their closed position. Top up with applicable hydraulic oil if necessary (see table on page 63).

NOTE

A significant drop in fluid levels indicates leakage. The appropriate cold fluid level can be checked on the hydraulic oil dipstick.

Inspect all hydraulic hoses, tubes, fittings, valves, and rams for leaks and damage. Tighten loose fittings and replace damaged components.

Check all three pressure settings every 200 hours and adjust if necessary.

Hydraulic Filter

Replace the return line filter cartridge after every 200 operating hours. The battery must be removed to access the return filter (see "Service Tasks: Battery" on page 68).

Pressure Filter

Replace in-line filter cartridge after every 500 operating hours.

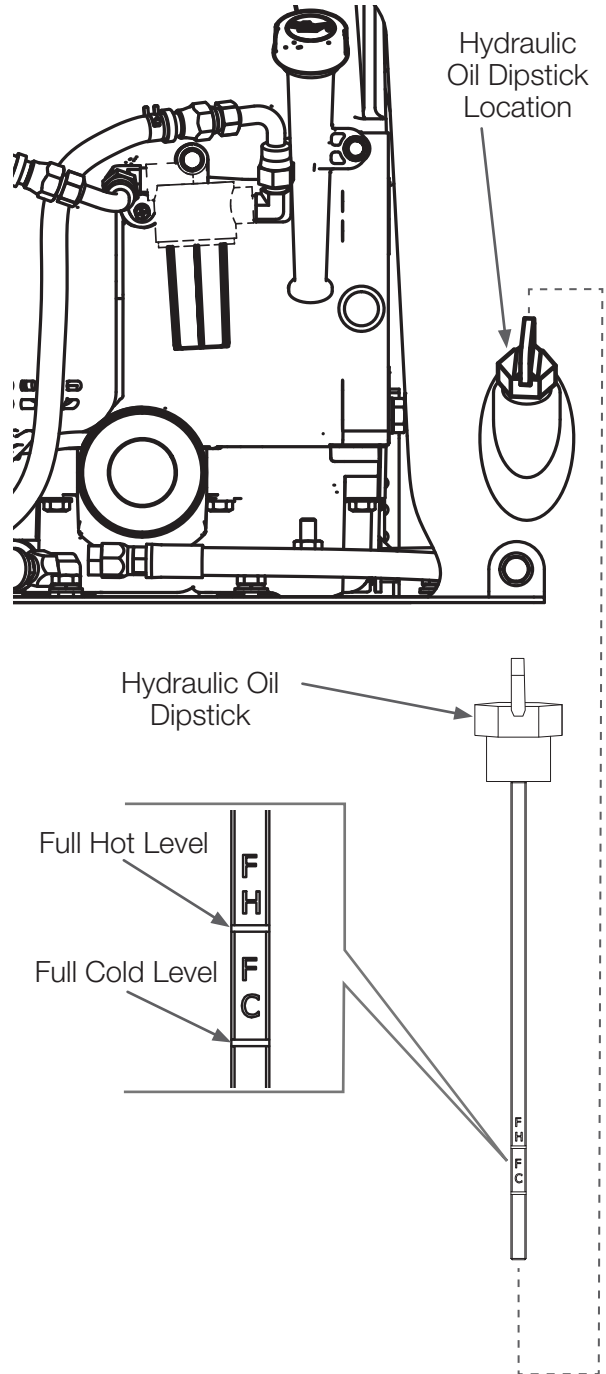

REPLACEMENT PARTS	
Description	Part Number
Return Filter Element	HA-000400
Pressure Filter Element	KS-100128

Hydraulic Oil Return
Filter Housing

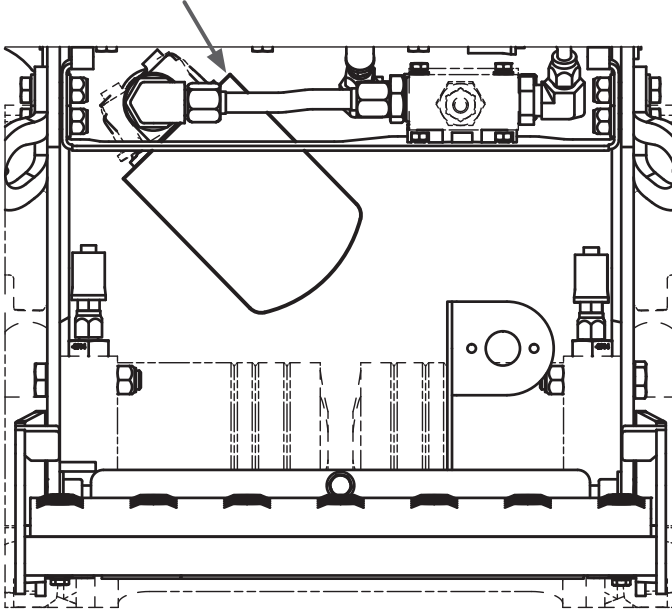

Rear view of the loader with battery cover removed and battery removed

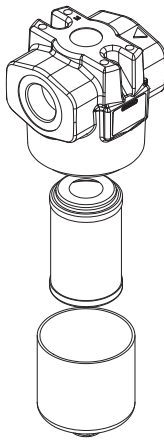

Hydraulic oil return filter housing exploded view showing the filter element

Hydraulic Pressure Settings

The hydraulic system has three pressure settings. These are referred to as the overcenter valve, the main system relief pressure, and the lift pressure.

Before any testing is carried out, run the engine and hydraulic system to warm the hydraulic oil. The oil cooler fan (if fitted) will engage at between 60 and 65°C (~145°F).

The pressure settings must be set as follows:

NOTE

All pressure settings are performed with the oil cooler fan (if fitted) on and engine running at full speed (3,150 rpm).

Overcenter Valve

Connect an accurate pressure gauge with a range 0 to 40 bar (0 to 600 psi) to the test point. The pressure should be set at 31 bar (450 psi).

If adjustment is required, slacken off the locknut. Using a 5mm hex key, wind the screw in to increase the pressure or out to reduce the pressure. Re-tighten the locknut when the adjustments are complete.

Main System Relief Pressure

Connect an accurate pressure gauge with a range 0 to 206 bar (3000 psi) to the test point. Check the pressure while pulling the tilt control lever at the end of the ram's stroke. The pressure should be set at 206 bar (3000 psi).

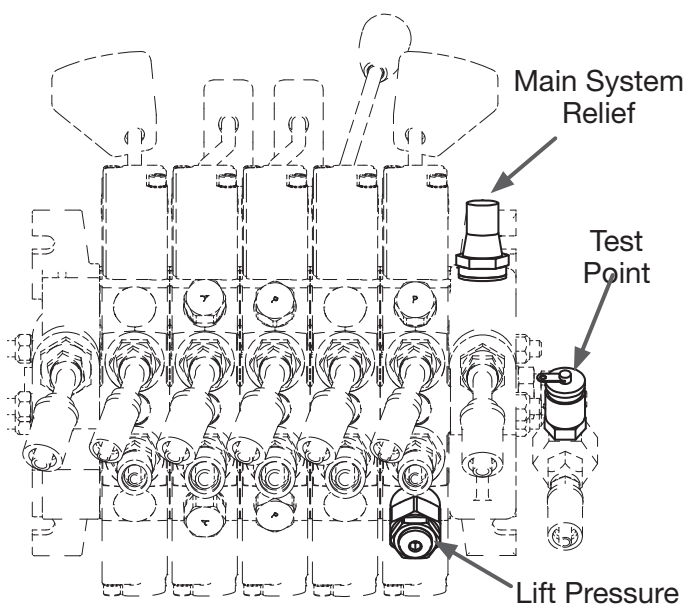

If adjustment is necessary, slacken off the locknut on the main pressure relief valve. Wind the screw in to increase the pressure or back off the screw to reduce the pressure. Re-tighten the locknut when adjustments are complete.

Lift Pressure

Connect an accurate pressure gauge with a range 0 to 206 bar (3000 psi) to the test point. With the boom fully raised, check the pressure while pulling the arm control lever at the end of the ram's stroke. The pressure should be set at 103 bar (1500 psi).

If adjustment is necessary, slacken off the locknut on the lift pressure relief cartridge. Using an Allen key, wind the screw in to increase the pressure or back off the screw to reduce the pressure. Tighten the locknut when adjustments are complete.

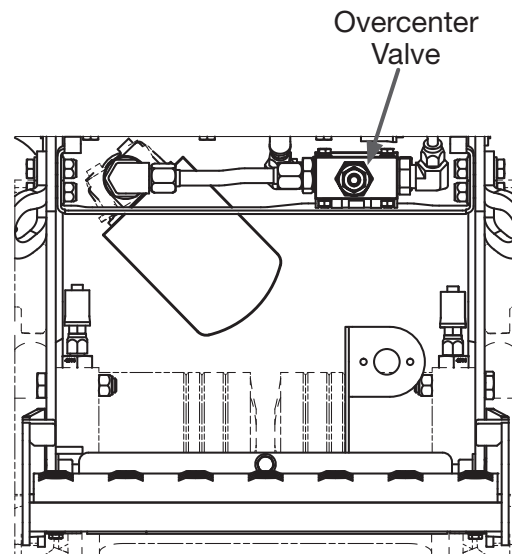

Hydraulic Fluid

Replace the hydraulic oil after every 1,000 operating hours, using Hydraulic Oil ISO 68. See "Specifications: PW220 Wheeled Loader" on page 81 and "Specifications: PT220 Tracked Loader" on page 83 for the hydraulic oil capacity.

The viscosity of an oil is identified by its "ISO Viscosity Rating" The ISO viscosity rating can be found on the oil container's label.

The Kanga hydraulic system operates at a oil temperature between 60 - 80°C (140 - 176°F). Using a hydraulic oil that meets these requirements will help eliminate costly machine downtime and reduce the overall operating cost of your equipment. Failure to use the correct hydraulic oil could create problems and cost you time and money.

NOTE

Kanga recommends for Australian conditions ISO 68. For colder American & European conditions ISO 46.

IMPORTANT

Check with your supplier before mixing hydraulic oils of different type, brand, or viscosity. Many oils are not compatible and damage to your hydraulic system could result. When changing oil viscosity, flush and clean the hydraulic system before adding new oil.

OIL VISCOSITY	AMBIENT TEMPERATURE CELSIUS	AMBIENT TEMPERATURE FAHRENHEIT
ISO 46 A medium weight oil for mid-range conditions with local temperatures ranges	-4° to +21°C	+25° to +70°F
ISO 68 A heavier oil for warm weather conditions with local temperature ranges	+4° to +32°C	+40° to +90°F

Hydraulic Oil Drain Plug

The hydraulic oil drain plug is located on the front side of the loader.

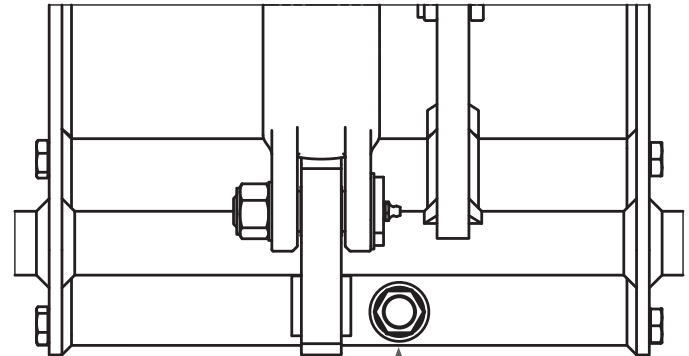

Hydraulic Oil Drain Plug

! DANGER

Secure the boom using the lock retaining device whenever performing work under the loader's arm. See "Loader Arm Maintenance" on page 52.

Hydraulic Controls

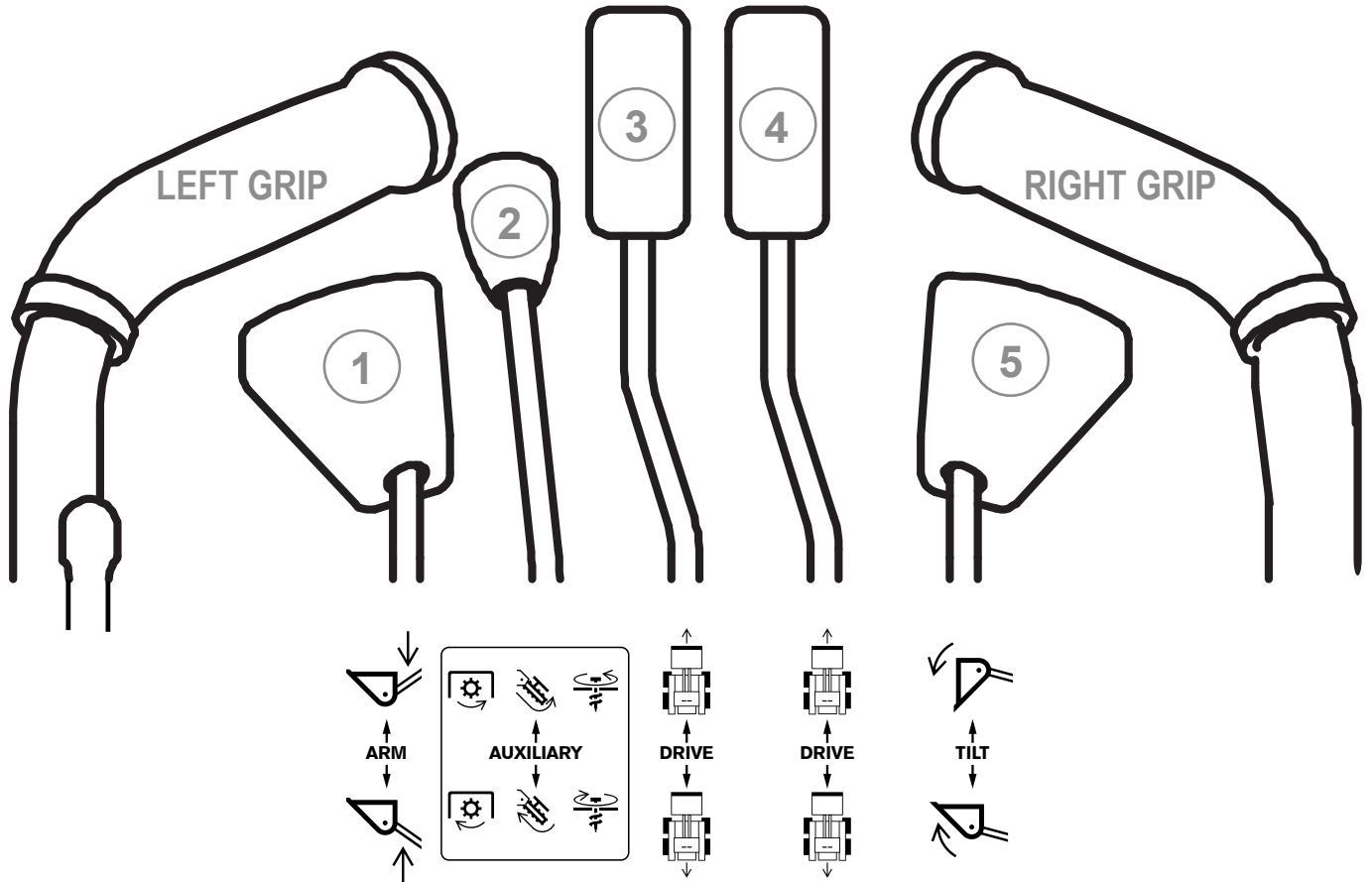

LEVER	CONTROLS	ACTION ON PUSH	ACTION ON PULL
1	MAIN LIFT ARM	LOWER ARM	RAISE ARM
2	AUX MOTOR	AUX MOTOR REVERSE	AUX MOTOR FORWARD
3	LEFT DRIVE	FORWARD SIMULTANEOUS APPLIED	REVERSE SIMULTANEOUS APPLIED
4	RIGHT DRIVE		
5	TILT	FORWARD (TIP)	TILT UP (CROWD)

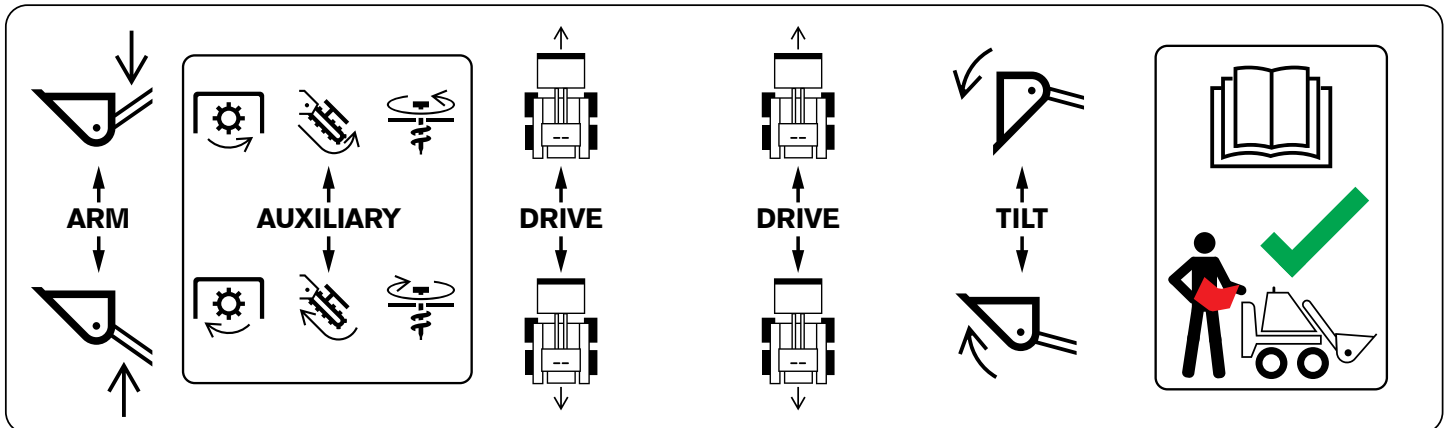

Service Tasks: Vapour Canister

The vapour canister prevents the release of fuel vapours to the atmosphere and it is an important part of the engine emissions control. It is recommended to replace the charcoal canister every 2 years.

Remove the canister clamps and the hoses connected to the canister to release it. Reinstall the hoses to the new vapour canister and clamp it in place. Ensure the hoses are firmly connected.

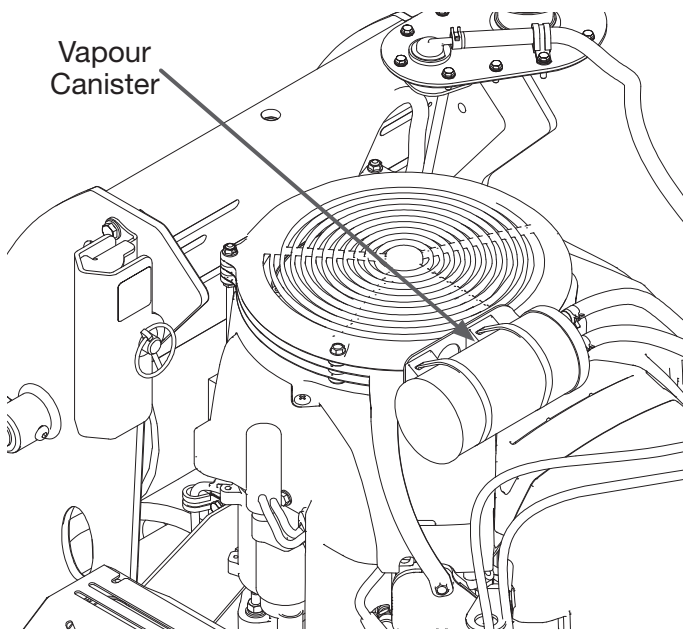

NOTE
In an event of a roll over the charcoal canister may become flooded with fuel and shall be replaced.

REPLACEMENT PARTS	
Description	Part Number
Vapour Canister 400cc	DL-004483
Spark Arrestor Kit	DL-005260

Service Tasks: Spark Arrestor

The spark arrestor prevents sparks from being ejected out of the exhaust muffler, which may initiate fires.

The spark arrestor must be inspected and cleaned after every 100 working hours. If its screen is damaged, it must be replaced immediately.

CAUTION

Wait until the exhaust muffler is cool before performing any maintenance.

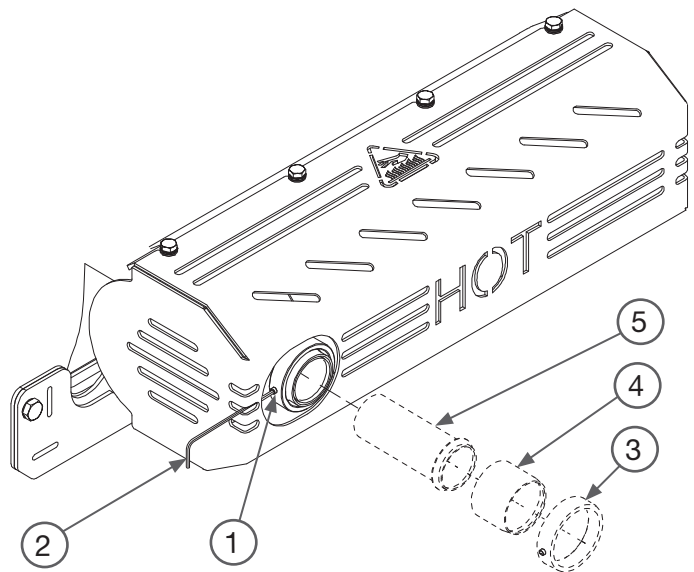

Disassembly Procedure

To disassemble the spark arrestor, loosen the set screw (1) using an Allen wrench (2) through the hole in the muffler heat guard. Remove the clamp (3) and the tailpipe extension (4) using pliers to twist it off.

Cleaning and Inspection

Remove the spark arrestor screen (5) with care and shake it to remove the soot. A soft non-metallic brush might be required to fully clean it. Inspect the screen for tears, rips, or any damage. Replace it if any damage is found.

Reassembly Procedure

Reinstall the spark arrestor in reverse order. Tighten the set screw to 4.2Nm (38 lb·in).

Service Tasks: Grease Nipples

Grease

After every 9-10 operating hours, grease each of the linkage pins, using an appropriate grease (multi-purpose pin grease). During greasing, also inspect for wear.



CAUTION

The frequency of re-greasing depends on the workload and the severity of the working conditions. Re-greasing during the day of operation may be necessary.

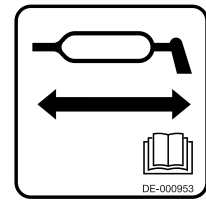
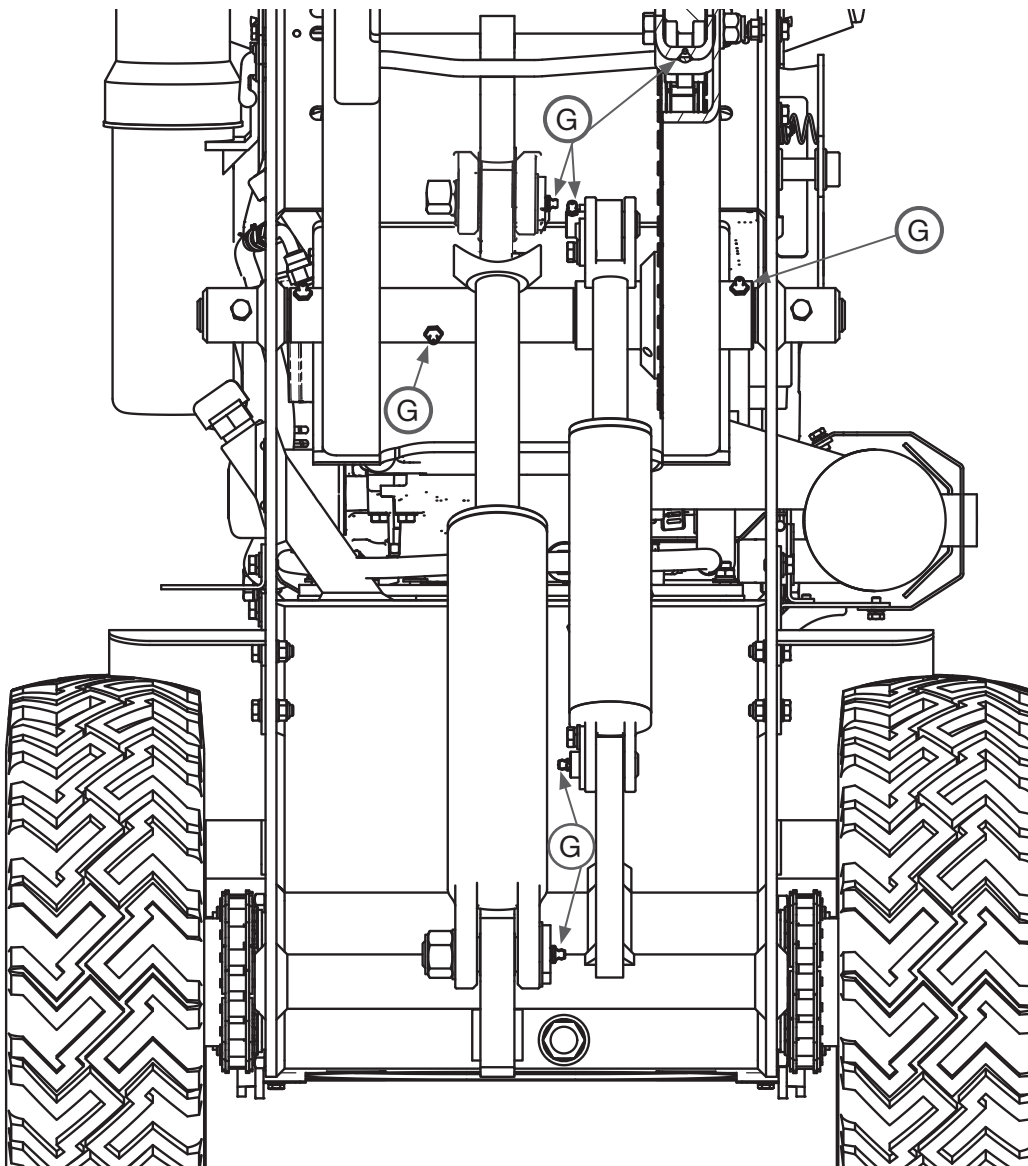

NOTE

90° grease nipple couplings are installed in restrictive areas to improve access for lubrication as shown.

NOTE

The location of the Grease-points are indicated above, It is important to grease the Loader regularly to prevent friction damage between moving parts from occurring.

Parking brake mechanism

The parking brake mechanism has a greasing point that must be frequently greased to ensure the correct actuation of the parking brake. See "Parking Brake" on page 33.

Remove the battery cover (see "Service Tasks: Battery" on page 68) to access the grease nipple on top of the parking brake mechanism.

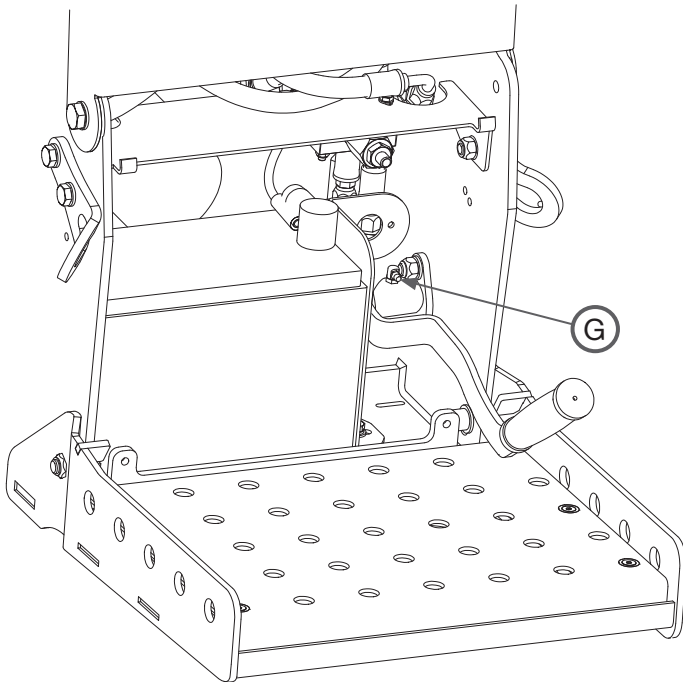

CAUTION

The parking brake mechanism must be frequently greased to ensure its effectiveness.

DANGER

Secure the boom using the lock retaining device whenever performing work under the loader's arm. See "Loader Arm Maintenance" on page 52.

Service Tasks: Battery

The battery provided with your loader is maintenance-free and may include an indicator at the top of the battery that displays its condition according to a displayed colour. Ensure that the terminals are tightened and that covers and battery leads are not damaged.

Removing the battery

The battery should be removed to allow access to the hydraulic oil return filter (see "Service Tasks: Hydraulics" on page 60) or to be replaced.

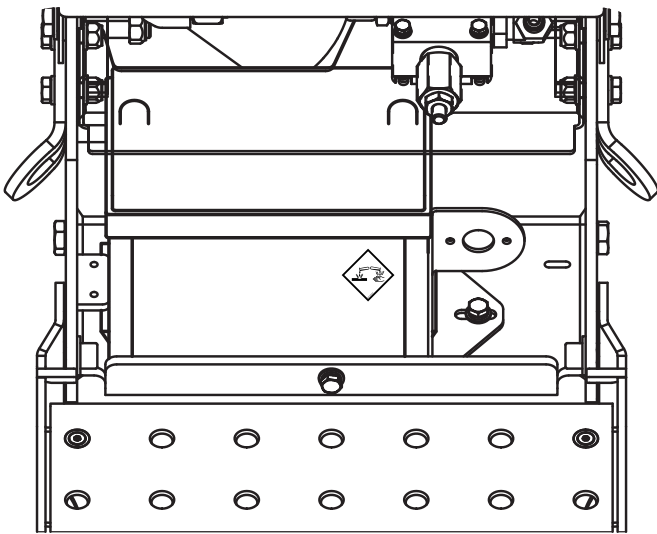

To access the battery, remove the battery cover by undoing the screws at the lower part of the cover and swinging the cover up.

Disconnect the negative pole (left hand-side) first and then disconnect the positive pole (right hand-side). Release the latches that hold the battery and carefully remove the battery from its cradle.

Reinstalling the battery

Lubricate the battery terminals with petroleum jelly. Place the battery, adjust the brackets* accordingly and latch it in place. Connect the positive pole (right hand-side) first and then the negative pole (left hand-side). Ensure the connectors are tightened.

Reinstall the battery cover by hanging it on the swing tabs and screwing back the bolt to hold the cover in place.

WARNING

The 12V battery contains sulphuric acid that is highly corrosive which can result in chemical burns to skin, flesh and materials.

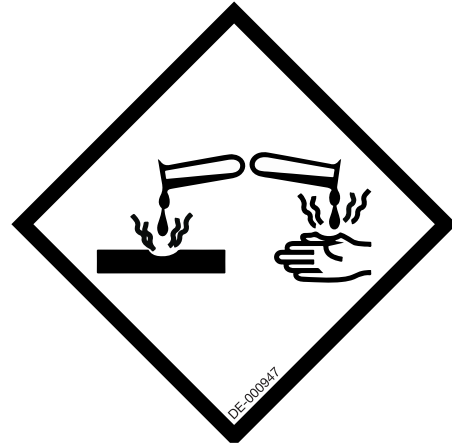

NOTE

Do not connect the battery in reverse polarity. This will short circuit the battery charging system and damage it severely.

REPLACEMENT BATTERY	
Description	Part Number
Battery (Australia / New Zealand)	DL-000605
Battery (USA and other regions)*	Consult your Kanga Dealer

*Loaders for USA and other regions are equipped with a universal size battery tray and clamp.

NOTE

Honda recommends a 12V 36Ah battery for general use. For severe use (e.g. cold ambient temperature, frequent starts) a battery with a higher capacity (Ah and/or CCA) might be required. Consult your Kanga dealer or an auto electrician.

Service Tasks: Pivot Pins

Bottom Pivot Pins

Before each use, visually inspect all pivot pins for signs of wear, damage, or failure. At every 200 operating hours, thoroughly inspect all pivot pins and bushes for wear and damage. Please refer to "Service Tasks: Grease Nipples" on page 66.

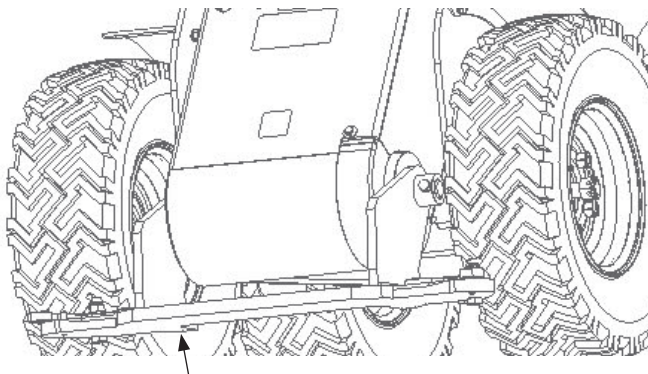

Attachment Plate

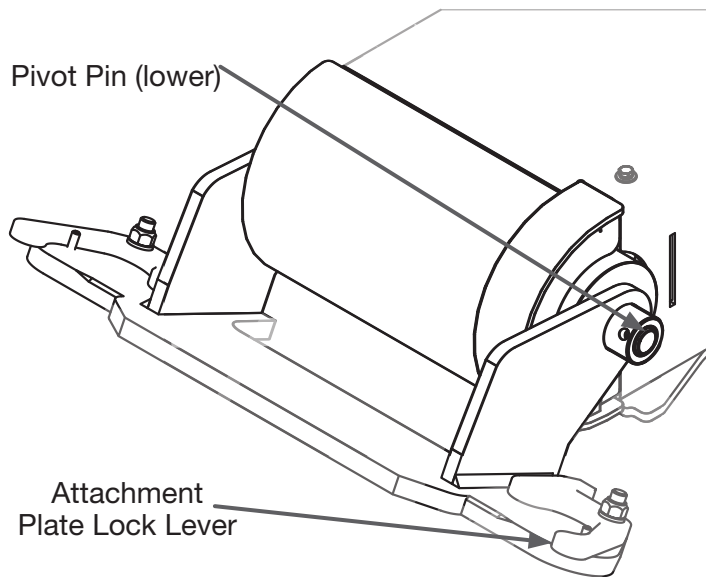

REPLACEMENT PARTS	
Description	Part Number
Attachment Plate	DL-000320
Top Pivot Arm Pin	DL-000350
Lower Pivot Arm Pin	DL-000351
Attachment Plate Lock Lever	DL-000370

Service Tasks: Tilt Chain

Tilt Chain

Check the tension of tilt chain after the first 20 hours of operation and every 200 operating hours thereafter. If the slack exceeds 10mm (3/8") adjustment becomes necessary.

Adjustment Procedure

Slacken adjuster screw Lock Nut (1)

Slacken adjuster block Clamp Nut (3)

Turn Adjuster Screw (2) clockwise to increase chain tension counter clockwise to decrease chain tension.

Chain tension is correct when the middle of the non adjustment loop of the chain can be moved 10mm (3/8").

When adjustment is correct, tighten Lock Nut (1) and Adjuster (3).

REPLACEMENT PARTS	
Description	Part Number
Chain Tensioners	DL-003571
Drive Chain Link	L-117700

DANGER

Secure the boom using the lock retaining device whenever performing work under the loader's arm. See "Loader Arm Maintenance" on page 52.

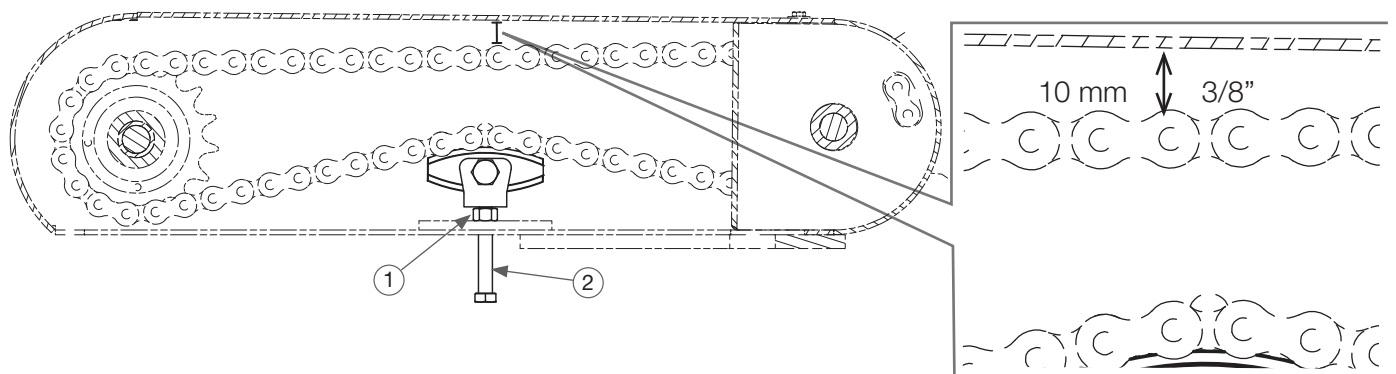
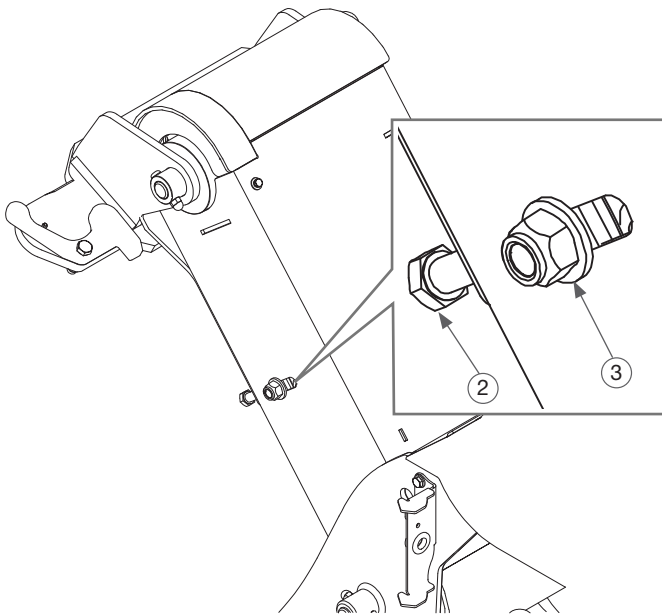

Service Tasks: Tyres and Tyre Pressure

Visually check tyres on a daily basis. Check tyre pressure every 50 operating hours, and check for wear and damage to tyres and tracks. Tyre pressure must be maintained to the following specifications:

KANGA 2 SERIES LOADER TYRE PRESSURE GROSS			
Model	Tyre size & type	Recommended Pressure	
		kPa	psi
PT220	400 x 8 - 8 PLY	379 - 517	55 - 75
PW220	570 x 8 - 4 PLY COMBO	220	32

REPLACEMENT PARTS	
Description	Part Number
Rim suit Kid Track and Wheel	DL-001315-BL
Tube suit Track Drive	DL-001316
Tube Suit Combo	DL-003391
PT220 Tyre Track Drive	DL-001317
PW220 Tyre Lug/Turf Combo	DL-003390
Wheel Studs	FA-000490
Wheel Nuts	FA-000530

NOTE

The Tyre pressures in track models are to be kept at a minimum 55 psi to prevent slipping with a maximum pressure not to exceed 75 psi. Adjust as required to accommodate for wear.

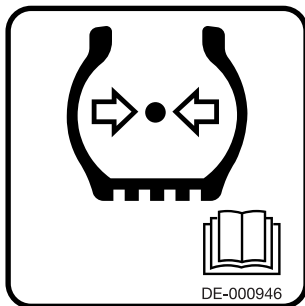

CAUTION

Maintain correct tyre pressure for all loader tyres.

Service Tasks: Visual Inspection

Check all over machine for loose bolts, cracks, and dents after every 100 operating hours. Tighten loose bolts, and replace if worn or damaged.

Inspections and Checks

Before each day's operation of the Kanga 2 Series Loader, the operator **MUST** perform the inspection and checks as outlined in the "Daily Checklist" on page 50.

The purpose of the operator's inspection is to keep the equipment in a safe working condition and to detect any signs of malfunctioning during normal operations between scheduled maintenance checks. While it may not be the operator's responsibility to perform mechanical maintenance, they should be thoroughly familiar with the unit, as this involves their own safety.

Many costly maintenance jobs can be prevented through observance of the following operator maintenance inspections and checks by Kanga 2 Series Loader operators.

For expert advice and quality service, consult an expert repairer. We recommend an authorised Kanga repairer. The owner should retain evidence that proper maintenance has been performed as prescribed. A claim against a warranty will not qualify if it results from lack of maintenance and not from defective material or authorised workmanship

CAUTION

DO NOT operate a Kanga 2 Series Loader that is known to be damaged or malfunctioning. Remove the key from the ignition and Tag Out the machine using an "Out of Service" tag and contact your Service Agent.

NOTE

Defective components and/or equipment malfunctions can jeopardise the safety of the operator and other personnel and can cause extensive damage to the unit. Remember, a poorly maintained unit could become a great operational hazard.

Service Tasks: Electrics

Main Fuse

The main electric system is protected by a 25 A mini fuse located close to the battery. Remove the battery cover (see "Service Tasks: Battery" on page 68) to access it.

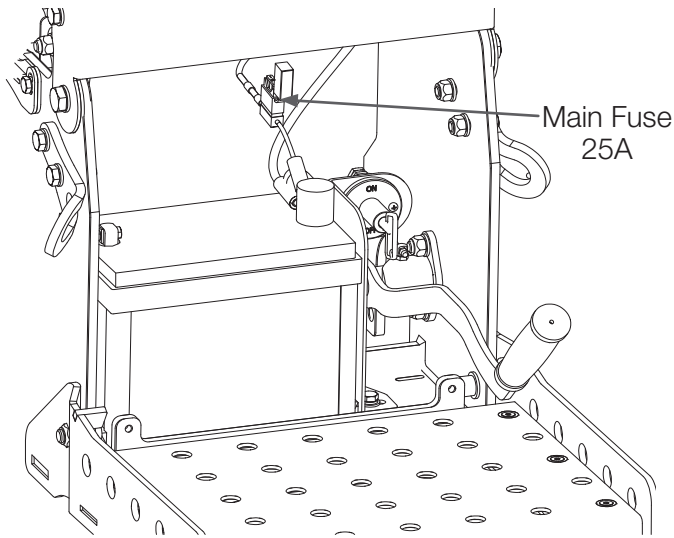

Switch Fuse

The key switch mini fuse (30 A) is located inside the side console. Remove the two bolts of the side console to access it.

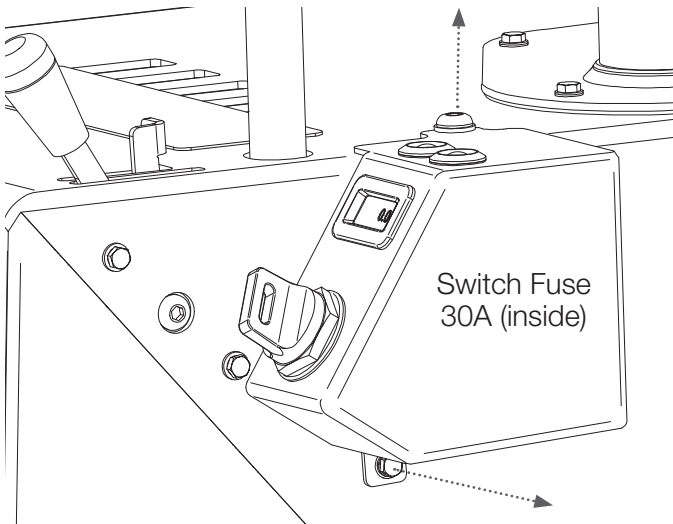

Auxiliary Power Fuse

The auxiliary power fuse holder is located under the cowl on the right hand side. It holds fuses for the array of accessories that can be installed to your Kanga Loader (see "Accessories" on page 35).

The circuits and fuses capacities are identified by pictograms as shown below:

15A		Warning Lights 15A
20A		Horn 20 A
DE-000639		Rearwards Beeper 20 A
SPARE		(Not used)

NOTE:

The above decal, fusebox and harness is only installed, when these optional features are requested.

WARNING

Always replace a fuse with one that has the specified amperage rating. Using a fuse with a higher amperage rating can cause severe wire damage and could start a fire. Seek assistance of a qualified auto electrician or consult your Kanga Dealer Service for more information.

Service Intervals and Records

MAINTENANCE INTERVAL	TYPE	MIN	MIN	MAJ	MIN	MAJ	MIN	MAJ	MIN	MAJ	MIN	MAJ	MIN	MAJ	MIN	MAJ	MIN	
	HOURS	20	100	200	300	400	500	600	700	800	900	1000	1100	1200	1300	1400	1500	
ENGINE OIL		R	R	R	R	R	R	R	R	R	R	R	R	R	R	R	R	R
ENGINE OIL FILTER		R	R	R	R	R	R	R	R	R	R	R	R	R	R	R	R	R
AIR FILTER ELEMENT *		I	R	R	R	R	R	R	R	R	R	R	R	R	R	R	R	R
AIR PRE FILTER FOAM *		I	R	R	R	R	R	R	R	R	R	R	R	R	R	R	R	R
FUEL FILTER *		I	I	R	I	R	I	R	I	R	I	R	I	R	I	R	I	I
SPARK PLUG		A	A	R	A	R	A	R	A	R	A	R	A	R	A	R	A	A
SPARK ARRESTOR**		I	C	C	C	C	C	C	C	C	C	C	C	C	C	C	C	R
IDLE SPEED		-	-	A	-	A	-	A	-	A	-	A	-	A	-	A	-	-
VALVE CLEARANCE		-	-	A	-	A	-	A	-	A	-	A	-	A	-	A	-	-
COMBUSTION CHAMBER		-	-	-	-	-	-	-	-	-	-	C	-	-	-	-	-	-
FUEL LINES		I	I	I	I	I	I	I	I	I	I	I	I	I	I	I	I	R
HYDRAULIC HOSE/TUBE		I	I	I	I	I	I	I	I	I	I	I	I	I	I	I	I	I
HYDRAULIC FLUID		I	I	I	I	I	I	I	I	I	I	R	I	I	I	I	I	I
HYDRAULIC RETURN FILTER				R		R		R		R		R		R		R		
TILT CHAIN		A	I	A	I	A	I	A	I	A	I	A	I	A	I	A	I	I

DAILY	ITEMS TO BE CHECKED ON A DAILY BASIS																	
	HOURS	8	8	8	8	8	8	8	8	8	8	8	8	8	8	8	8	
AIR PRE FILTER FOAM *		C	C	C	C	C	C	C	C	C	C	C	C	C	C	C	C	C
VISUAL CHECK (CRACKS, WEAR)		I	I	I	I	I	I	I	I	I	I	I	I	I	I	I	I	I
GREASE NIPPLES/PINS		L	L	L	L	L	L	L	L	L	L	L	L	L	L	L	L	L

TYRES/TYRE PRESSURE	ITEMS TO BE CHECKED AT REGULAR INTERVALS																	
	HOURS	50	50	50	50	50	50	50	50	50	50	50	50	50	50	50	50	
TYRES		I	I	I	I	I	I	I	I	I	I	I	I	I	I	I	I	I
TYRE PRESSURE		I	I	I	I	I	I	I	I	I	I	I	I	I	I	I	I	I

Key

R	Replace
C	Clean as required
L	Lubricate as necessary
A	Adjust as necessary
I	Inspect, fill up, tighten, or replace as necessary

* Service may be required at more regular intervals if working in dusty conditions.

** If applicable

SERVICE KITS	
Description	Part Number
Service Kit Minor (no oil)	SER-000187
Service Kit Major (no oil)	SER-000188
Service Kit Minor (includes oil)	SER-000189
Service Kit Major (includes oil)	SER-000190

Maintenance Schedule

MODEL	MINOR SERVICE 100Hr	MAJOR SERVICE 200Hr	MINOR SERVICE 300Hr	MAJOR SERVICE 400Hr	MINOR SERVICE ¹ 500Hr
	DATE _____ SERVICE STAMP	DATE _____ SERVICE STAMP	DATE _____ SERVICE STAMP	DATE _____ SERVICE STAMP	DATE _____ SERVICE STAMP
PT / PW SERIES	MAJOR SERVICE 600Hr	MINOR SERVICE 700Hr	MAJOR SERVICE 800Hr	MINOR SERVICE 900Hr	MAJOR SERVICE ^{1,2} 1000Hr
	DATE _____ SERVICE STAMP	DATE _____ SERVICE STAMP	DATE _____ SERVICE STAMP	DATE _____ SERVICE STAMP	DATE _____ SERVICE STAMP

PW220 & PT220 SERIES

Maintenance Schedule (continued)

MODEL	MINOR SERVICE 1100Hr	MAJOR SERVICE 1200Hr	MINOR SERVICE 1300Hr	MAJOR SERVICE 1400Hr	MINOR SERVICE ¹ 1500Hr
	DATE _____ SERVICE STAMP	DATE _____ SERVICE STAMP	DATE _____ SERVICE STAMP	DATE _____ SERVICE STAMP	DATE _____ SERVICE STAMP
PT / PW SERIES	MAJOR SERVICE 1600Hr	MINOR SERVICE 1700Hr	MAJOR SERVICE 1800Hr	MINOR SERVICE 1900Hr	MAJOR SERVICE ^{1,2} 2000Hr
	DATE _____ SERVICE STAMP	DATE _____ SERVICE STAMP	DATE _____ SERVICE STAMP	DATE _____ SERVICE STAMP	DATE _____ SERVICE STAMP

Note The warranty on the equipment is subject to the periodic maintenance being carried out at the intervals specified. If a service provider other than Kanga Loaders is used, maintenance records from the trade-qualified provider may be required to support any claim.

Only genuine Kanga spare parts should be used during servicing.

¹Pressure hydraulic oil filter requires changing for 500h service.

²Hydraulic oil requires changing for 1000h service.

PW220 & PT220 SERIES

Troubleshooting Guide

This section contains troubleshooting information to be used for locating and correcting problems which may develop with your Kanga Loader. Troubleshooting and maintenance information relating to the engine are contained in the engine manual.

Arms

TROUBLE	PROBABLE CAUSE	REMEDY
Arm will not rise.	Load capacity exceeded.	Reduce load. Load should not exceed the specified Rated Operating Capacity (ROC).
	Hydraulic system oil level low.	Check oil and replenish as necessary. Oil level should not change. Leaks may be present.
	Damaged or blocked hydraulic line.	Remove line and remove any obstructions or replace line as necessary. Contact Service Agent.
	Malfunctioning hydraulic pump.	Replace hydraulic pump as necessary. Contact Service Agent.
	Worn control valve spool.	Check pressure delivery from control valve. Contact service agent.
	Lift control valve relief set too low, allowing oil to return to reservoir.	Adjust relief valve to proper setting. Contact service agent.
	Excessive oil leak past lift cylinder piston seal.	Repair or replace cylinder as necessary.
Arm will not lower.	Hydraulic oil system low.	Check oil and replenish as necessary. Oil level should not change. Leaks may be present.
	Damaged or blocked hydraulic line.	Remove line and remove any obstructions or replace line as necessary. Contact Service Agent.
	Malfunctioning pump.	Replace hydraulic pump as necessary. Contact Service Agent.
	Worn control valve spool.	Check pressure delivery from control valve. Contact service agent. Contact Service Agent.
	Control rod or lever broken or disconnected.	Repair or replace control rod or lever.
Arm lowers with control lever in neutral.	Worn control valve spool.	Repair or replace valve as required. Contact Service Agent.
	Lift ram piston seal leaking.	Replace seals.
Arm will not rise, or rises slowly.	Lift control valve relief set too low allowing oil to return to reservoir.	Adjust relief valve to proper setting. Contact service agent.
	Worn control valve spool.	Check pressure delivery from control valve. Contact service agent.
	Excessive oil leak past lift cylinder piston seal.	Repair or replace cylinder as necessary.
	Control rod or lever broken or disconnected	Repair or replace control rod or lever.
	Hydraulic lines incorrectly connected at control valve.	Correctly connect line at control valve. Contact Service Agent.

Arms (continued)

TROUBLE	PROBABLE CAUSE	REMEDY
Arm rises and lowers erratically.	Lift control valve relief set too low, allowing oil to return to reservoir.	Adjust relief valve to proper setting.
	Hydraulic system oil low.	Check oil and replenish as necessary. Oil level should not change. Leaks may be present.
	Damaged or blocked line.	Remove line and remove any obstructions or replace line as necessary.
	Malfunctioning pump.	Repair or replace hydraulic pump as necessary.
	Worn control valve spool.	Check pressure delivery from control valve. Repair or replace valve as required.
	Excessive oil leak past lift cylinder piston seal.	Repair or replace cylinder as necessary.
	Arm pivot pin seized or otherwise damaged.	Replace pivot pin and bushing as necessary. Grease thoroughly.

Hydraulic Pump

TROUBLE	PROBABLE CAUSE	REMEDY
Flow from hydraulic pump erratic or non-existent.	Hydraulic system oil low.	Check oil and replenish as necessary. Oil level should not change. Leaks may be present.
	Damaged or blocked line.	Remove line and remove any obstructions or replace line as necessary. Contact Service Agent.
	Worn or chipped pump gears.	Replace pump gears as necessary.
	Worn or broken drive shaft or coupling.	Inspect drive shaft or coupling. Repair or replace as necessary.
Hydraulic pump noisy.	Air in hydraulic system.	Check suction side of hydraulic system for defects and repair as necessary. Ensure no leaks exist in the suction line.
	Hydraulic system oil low.	Check oil and replenish as necessary. Oil level should not change. Leaks may be present.
	Worn or broken drive shaft or coupling.	Inspect drive shaft or coupling. Repair or replace as necessary.
	Worn or chipped pump gears.	Replace hydraulic pump as necessary.

Drive System

TROUBLE	PROBABLE CAUSE	REMEDY
Machine will not drive forward or backward.	Hydraulic system oil low.	Check oil and replenish as necessary. Oil level should not change. Leaks may be present.
	Worn control valve spool.	Check pressure delivery from control valve. Repair or replace valve as required.
	Damaged or blocked line.	Remove line and remove any obstructions or replace line as necessary.
	Control rod or lever broken or disconnected.	Repair or replace control rod or lever.
	Hydraulic lines incorrectly connected at control valve.	Correctly connect line at control valve.
	Malfunctioning pump.	Repair or replace pump.

Drive System (continued)

TROUBLE	PROBABLE CAUSE	REMEDY
Machine drive speed is erratic.	Hydraulic system oil low.	Check oil and replenish as necessary. Oil level should not change. Leaks may be present.
	Damaged or blocked line.	Remove line and remove any obstructions or replace line as necessary.
	Binding drive motor(s).	Repair or replace motor(s) as necessary.
	Relief valve setting.	Adjust relief valve.

Auxiliary Hydraulic

TROUBLE	PROBABLE CAUSE	REMEDY
Attachment is slow or will not function.	Hydraulic system oil low.	Check oil and replenish as necessary. Oil level should not change. Leaks may be present.
	Damaged or blocked line.	Remove line and remove any obstructions or replace line as necessary.
	Malfunctioning pump.	Replace hydraulic pump as necessary.
	Worn control valve spool.	Check pressure delivery from control valve. Repair or replace valve as required.
	Attachment plate pivot pin seized or otherwise damaged.	Replace pivot pin and bushing as necessary. Grease thoroughly.
	Excessive oil leak past cylinder piston seal or motor rotating group.	Repair or replace cylinder motor as necessary.
	Control rod or lever broken or disconnected.	Repair or replace control rod or lever.

Engine

TROUBLE	PROBABLE CAUSE	REMEDY
Engine will not crank over.	Low battery output.	Recharge or replace battery.
	Loose, disconnected or broken battery cables.	Inspect cable(s) and tighten all connections. Repair or replace cables as necessary.
	Faulty starter.	Repair or replace starter.
	Faulty circuit wiring.	Check wiring continuity.
	Engine flooded.	Remove spark plug and crank.
	Isolator switch off (if equipped)	Turn the isolator switch on
	Emergency stop activated (if equipped)	Turn the button clockwise to release
Engine cranks but does not fire.	No fuel in tank.	Refill fuel tank.
	Spark plug fouled.	Check spark plug gap and clean or replace spark plug.
	Dirty fuel filter.	Clean or replace filter.
	Carburettor flooded.	Clear carburettor.
	Fuel valve closed.	Open valve.
Engine runs but stalls.	Spark plug fouled.	Check spark plug gap and clean or replace.
	Fuel valve closed.	Open valve.
	Low battery output.	Recharge or replace battery.
Engine lacks power.	Air filter restricted.	Clean or replace the air filter element.
	Fuel filter restricted.	Contact your Kanga Dealer for service/repair.
	Carburetor malfunction.	
	Ignition malfunction.	

Loader Specifications and Decals

Schematic: PW220 Loader with Wheels

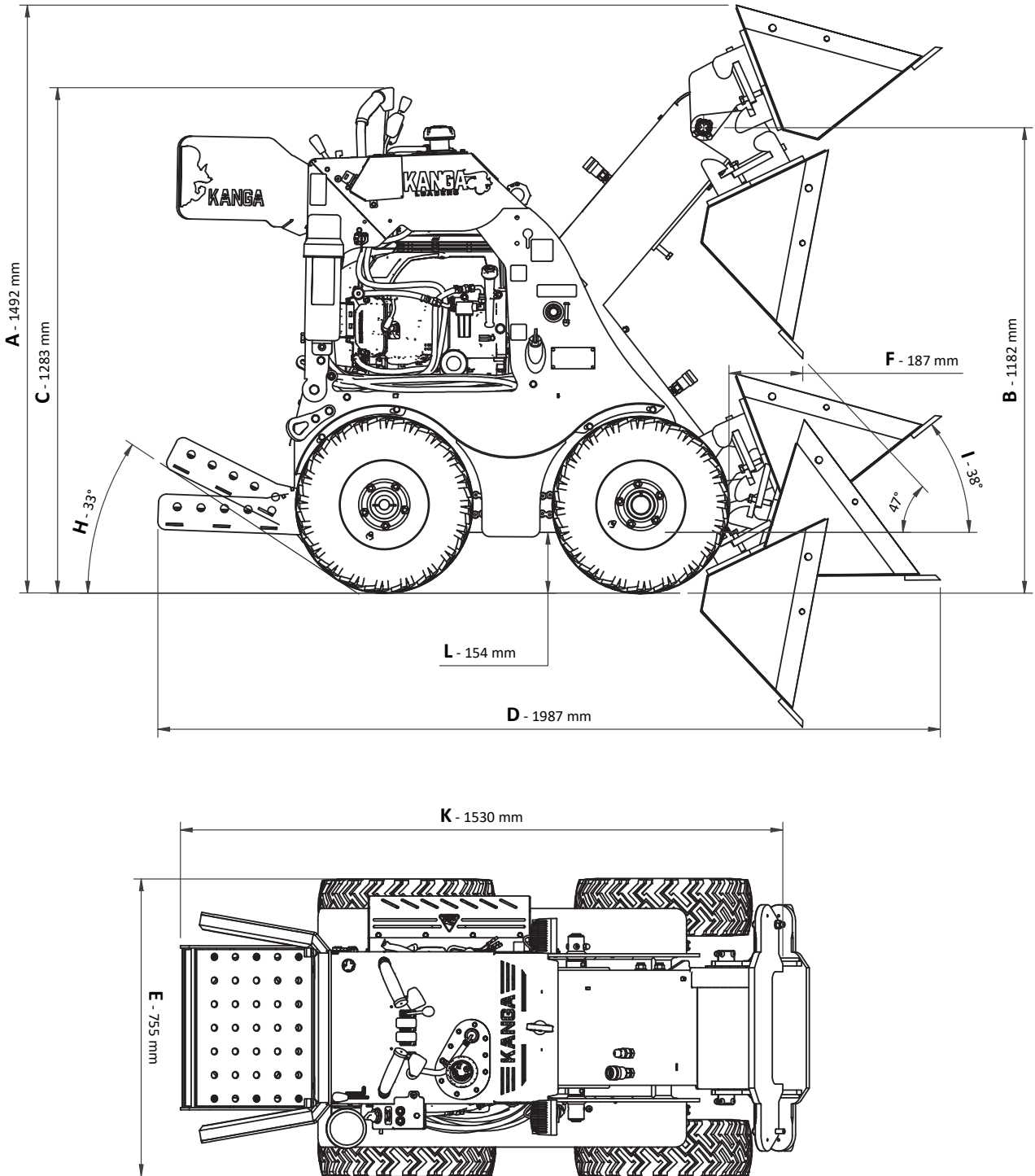

Specifications: PW220 Wheeled Loader

PERFORMANCE	PW220	
Tipping Load ¹ (0kg Bucket)	357 kg	785 lb
Tipping Load ¹ (40kg Kanga GP bucket)	317 kg	697 lb
Tipping Load ¹ (92kg Kanga 4 in 1 bucket)	265 kg	582 lb
Rated Operating Capacity (ROC) ¹ 0kg Bucket	178 kg	392 lb
Rated Operating Capacity (ROC) ¹ 40kg Kanga GP bucket	158 kg	348 lb
Rated Operating Capacity (ROC) ¹ 92kg Kanga 4 in 1 bucket	132 kg	291 lb
Maximum Travel Speed (Fast Mode)	5.4 kph	3.4 mph
Fuel Capacity (Petrol)	11.6 L	3.06 US gal
Loader Mass ²	444 kg	980 lb
ENGINE		
Manufacturer	Honda GXV630 (Petrol)	
Rated Power ³	15.5 kW & 3600 RPM	20.8 HP
DRIVE SYSTEM		
Drive Control	Soft Touch Hand Levers - Rubber Mounted	
Throttle Control	Hand Levers	
Wheels with Direct Drive Hydraulic Motor	Rear Wheels (x2)	
HYDRAULICS		
Gear Pump Displacement	8.3 cc/rev	0.51 cu in/rev
Pump Output	25.6L/min	6.7 US gal/min
System Pressure	203 bar	3000 PSI
Hydraulic Reservoir Capacity	51.5 L	13.6 US gal
BUCKETS		
GP Bucket Capacity (heaped / struck) ⁴	0.077 m ³ / 0.059 m ³	2.72 cu ft / 2.08 cu ft
HD 4-in-1 Bucket Capacity (heaped / struck) ⁴	0.084m ³ / 0.059 m ³	2.97 cu ft / 2.23 cu ft
DIMENSIONS		
A Max Operating Height (inc GP Bucket)	1492 mm	58.7"
B Height to Hinge Pin	1182 mm	46.5"
C Overall Height (No Warning Lights)	1238 mm	48.7"
D Overall Length With GP Bucket	1987 mm	78.2"
E Overall wheel width	755 mm	29.7"
F Bucket Reach at 47° (GP Bucket)	187 mm	7.4"
H Angle of Departure	33°	
I Max Roll Back (with GP Bucket)	38°	
J Bucket Width (GP Bucket)	809 mm	31.9"
K Overall Length Less Bucket	1530mm	60.2"
L Ground Clearance	154 mm	6.1"

1. Tipping load and Rated Operating Capacity (ROC) have been determined to ISO 14397-1. Refer to the section of the Operators Manual "Practice Safety at All Times" for Tipping Load and ROC values for the range of Kanga bucket and fork attachments. Note that ROC is 50% of the Tipping Load for wheel loaders and 45% for Kanga "over tire track" loaders.

2. Loader mass is the mass of the loader and fluids only. Specifically, this is the operating mass without the operator or bucket mass.

3. Power Rating is the net power of the production engine only as measured in accordance with SAE J 1349 at 3600 RPM. Mass production engines vary from this value. Actual power output for the engine installed in the delivered machine may vary depending on numerous factors. These factors can include operation speed of the engine in the application, environmental conditions, and other variables.

4. Volumes based on ISO 7546:1983.

Schematic: PT220 Loader with Tracks

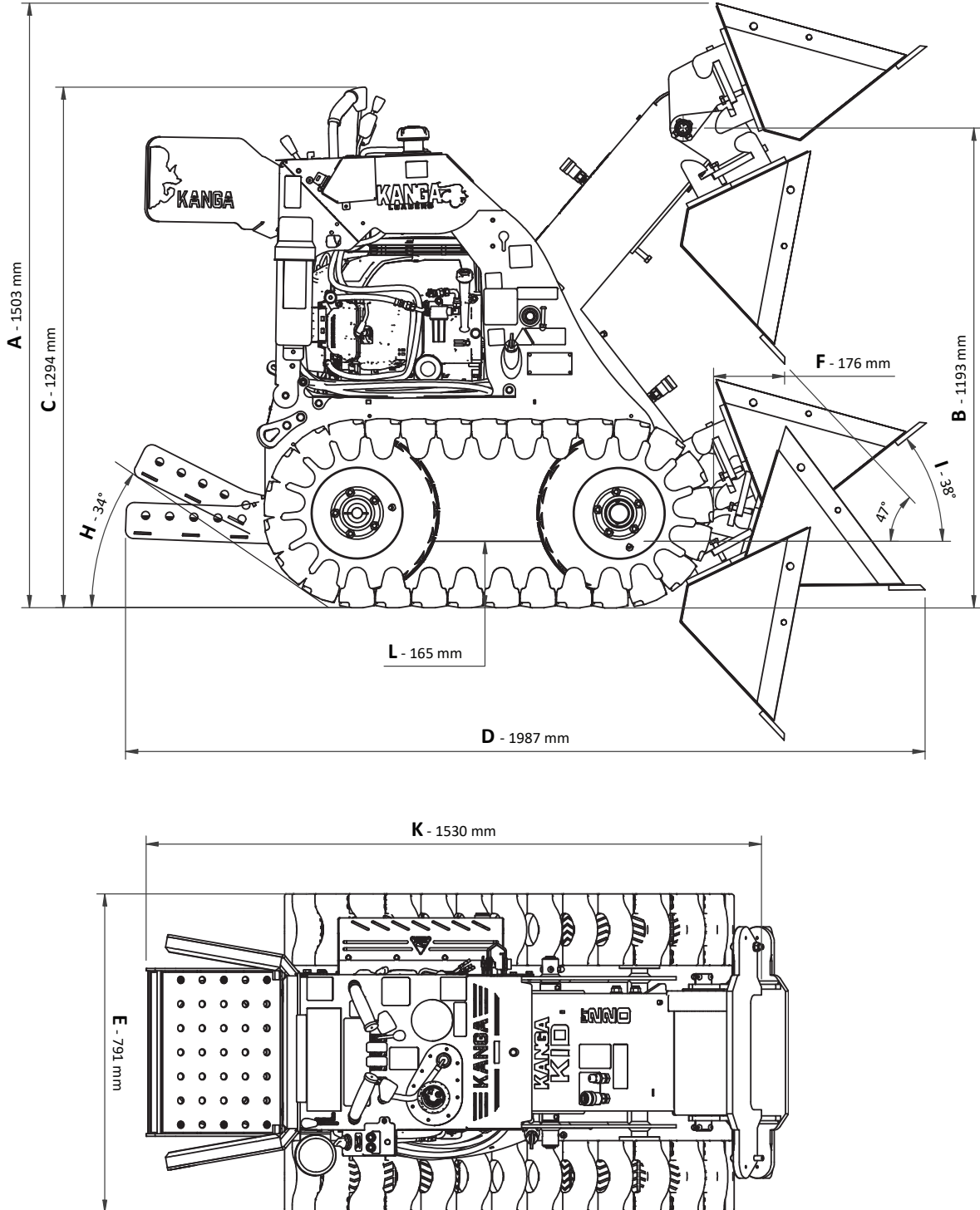

Specifications: PT220 Tracked Loader

PERFORMANCE	PT220	
Tipping Load ¹ (0kg Bucket)	361 kg	794 lb
Tipping Load ¹ (40kg Kanga GP bucket)	321 kg	706 lb
Tipping Load ¹ (92kg Kanga 4 in 1 bucket)	269 kg	591 lb
Rated Operating Capacity (ROC) ¹ 0kg Bucket	162 kg	357 lb
Rated Operating Capacity (ROC) ¹ 40kg Kanga GP bucket	144 kg	318 lb
Rated Operating Capacity (ROC) ¹ 92kg Kanga 4 in 1 bucket	121 kg	266 lb
Maximum Travel Speed (Fast Mode)	5.5 kph	3.4 mph
Fuel Capacity (Petrol)	11.6 L	3.06 US gal
Loader Mass ²	472 kg	1040 lb
ENGINE		
Manufacturer	Honda GXV630 (Petrol)	
Rated Power ³	15.5 kW @ 3600 RPM	20.8 HP
DRIVE SYSTEM		
Drive Control	Soft Touch Hand Levers - Rubber Mounted	
Throttle Control	Hand Levers	
Wheels with Direct Drive Hydraulic Motor	Rear Wheels (x2)	
HYDRAULICS		
Gear Pump Displacement	8.3 cc/rev	0.51 cu in/rev
Pump Output	25.6 L/min	6.7 US gal/min
System Pressure	203 bar	3000 PSI
Hydraulic Reservoir Capacity	51.5 L	13.6 US gal
BUCKETS		
GP Bucket Capacity (heaped / struck) ⁴	0.077 m ³ / 0.059 m ³	2.72 cu ft / 2.08 cu ft
HD 4-in-1 Bucket Capacity (heaped / struck) ⁴	0.084m ³ / 0.059 m ³	2.97 cu ft / 2.23 cu ft
DIMENSIONS		
A Max Operating Height (inc GP Bucket)	1503 mm	59.2"
B Height to Hinge Pin	1193 mm	47.0"
C Overall Height (No Warning Lights)	1294 mm	50.9"
D Overall Length with GP Bucket	1987 mm	77.4"
E Overall Track width	791 mm	31.1"
F Bucket Reach at 47° (GP Bucket)	176 mm	6.9"
H Angle of Departure	34°	
I Max Roll Back (including GP Bucket)	38°	
J Bucket Width (GP Bucket)	809 mm	31.9"
K Overall Length Less Bucket	1530 mm	60.2"
L Ground Clearance	165 mm	6.5"

1. Tipping load and Rated Operating Capacity (ROC) have been determined to ISO 14397-1. Refer to the section of the Operators Manual "Practice Safety at All Times" for Tipping Load and ROC values for the range of Kanga bucket and fork attachments. Note that ROC is 50% of the Tipping Load for wheel loaders and 45% for Kanga "over tire track" loaders.

2. Loader mass is the mass of the loader and fluids only. Specifically, this is the operating mass without the operator or bucket mass.

3. Power Rating is the net power of the production engine only as measured in accordance with SAE J 1349 at 3600 RPM. Mass production engines vary from this value. Actual power output for the engine installed in the delivered machine may vary depending on numerous factors. These factors can include operation speed of the engine in the application, environmental conditions, and other variables.

4. Volumes based on ISO 7546:1983.

Decals: PT220/PW220 Loader

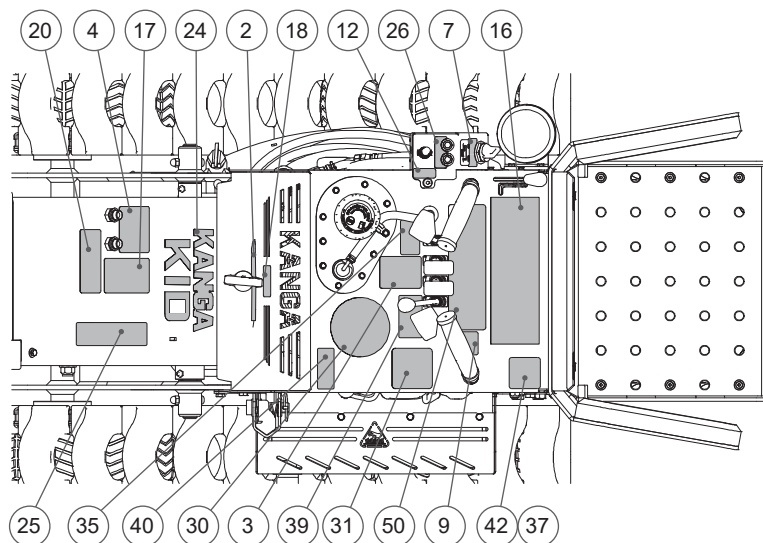
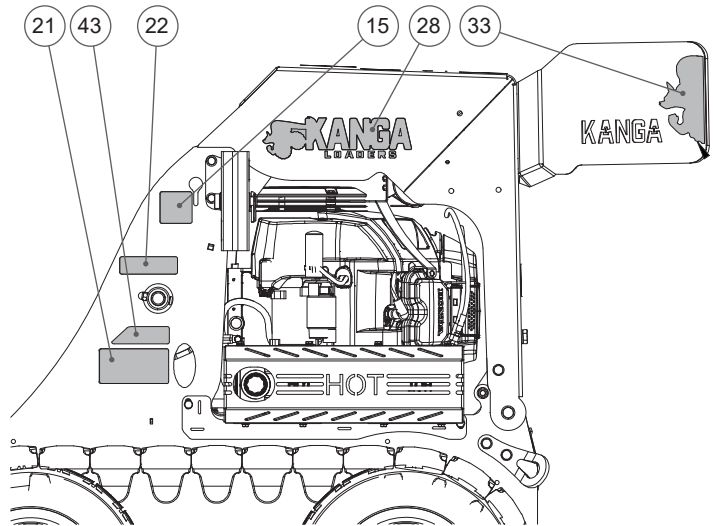
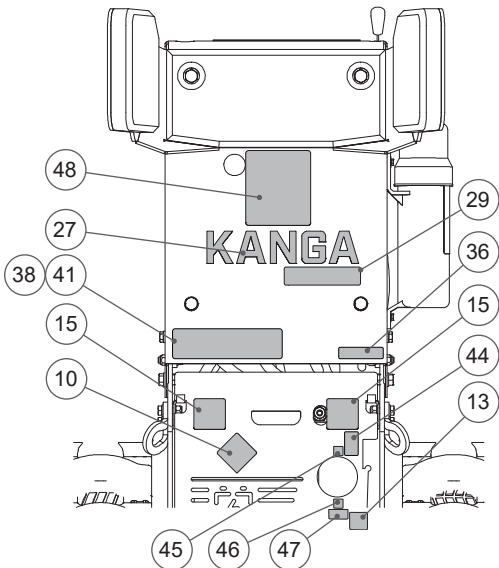
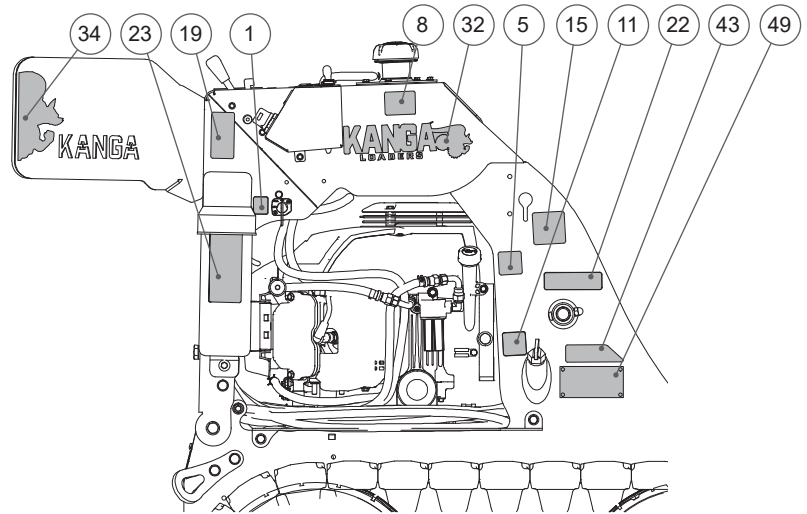
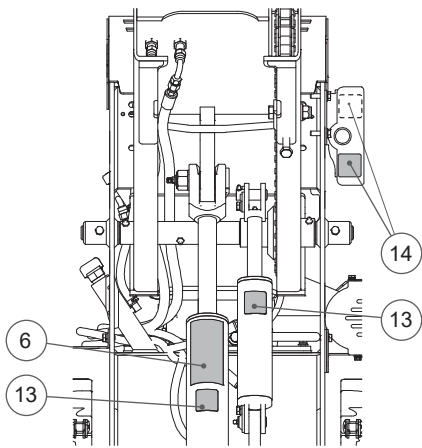

* Branding decals may vary in different countries. Contact your local branch before ordering.

ITEM	QTY	REGION/ MODEL	SIZE (WxH) [mm]	PART NUMBER	DESCRIPTION	DKIT
1	1		25x30	DE-000641	FUEL SHUT-OFF	2059/2060
2	1		100x24	DE-000837	HONDA AUSTRALIA APPROVED	2059/2060
3	1		55x70	DE-000929	ISO FUEL TANK FLAMABLE LIQUID	2059/2060
4	1		80x80	DE-000931	ISO KANGA KID SAFE CONNECTION	2059/2060
5	1		40x40	DE-000934	ISO ENGINE OIL DIPSTICK	2059/2060
6	1		60x120	DE-000942	ISO KID LIFT ARM LOCK	2059/2060
7	1		49x29	DE-000943	ISO 2 SERIES IGNITION	2059/2060
8	1		54x42	DE-000945-SM	ISO MAX. FILL LEVEL (SMALL)	2059/2060
9	1		40x40	DE-000946	ISO TYRE PRESSURE	2059/2060
10	1		70x70	DE-000947	ISO CORROSIVE	2059/2060
11	1		40x40	DE-000950	ISO HYDRAULIC OIL	2059/2060
12	1		16x40	DE-000952	ISO HEADLIGHT CONTROL	2059/2060
13	3		40x40	DE-000953	ISO GREASE POINT	2059/2060
14	2		40x40	DE-000917	2 SERIES ARM CILINDER LOCK	
15	4		40x40	DE-000954	LASHING POINT	2059/2060
16	1		255x90	DE-000955-1	KANGA 2 SERIES -MODEL 220	2059/2060
17	1		60x120	DE-000957	ISO CRUSHED HAND LARGE	2059/2060
18	1		55x55	DE-000959	ISO LIFTING POINT	2059/2060
19	1		40x80	DE-000960	REMOVE KEY BEFORE MAINTENANCE	2059/2060
20	1		110x55	DE-000961	CAUTION FLUID UNDER PRESSURE	2059/2060
21	1		120x60	DE-000962	HOT EXHAUST	2059/2060
22	2		100x30	DE-000981	RATED OP. CAPACITY REFER TO MANUAL	2059/2060
23	1		60x120	DE-002064	CAUTION READ MANUAL BEFORE USE	2059/2060
24	1		168x124	DE-002216	KANGA KID YELLOW & WHITE	2059/2060
25	1	PW220	50x200	DE-002228	MODEL CODE - PW220	2059
	1	PT220	50x200	DE-002229	MODEL CODE - PT220	2060
26	1		55x32	DE-002230	ISO LED DASH-P220	2059/2060
27	1		265x56	DE-002237	KANGA	2059/2060
28	1		255x70	DE-002238	KANGA LOGO, BLACK ARMS LHS	2059/2060
29	1	PW220	138x28	DE-002239	PW220 - REAR TANK HORIZONTAL	2059
	1	PT220	138x28	DE-002240	PT220 - REAR TANK HORIZONTAL	2060
30	1		100 DIA	DE-002241	BUILT TOUGH BADGE	2059/2060
31	1		70x70	DE-002242	GOT VIDS AND PICS	2059/2060
32	1		220X60	DE-002243	KANGA LOADER LH YELLOW	2059/2060
33	1		85x156	DE-002244-LHS	HALF KANGAROO - LHS	2059/2060
34	1		85x156	DE-002244-RHS	HALF KANGAROO - RHS	2059/2060
35	1	USA	82x43	DE-000538	P65 WARNING	2063
36	1	USA	60x18	DE-000633	COUNTRY OF ORIGIN AUSTRALIA	2063
37	1	USA	63x70	DE-000980	USA SERVICE REPAIRS AND SPARES	2063
38	1	USA	250x47	DE-002232	KANGALOADER.COM USA	2063
39	1	USA	82x43	DE-00XXXX	YEAR 20XX EMISSION CONTROL INFO	
40	1	AUS	90x35	DE-000046	BEFORE YOU DIG - SMALL	2061
41	1	AUS	250x47	DE-000492	KANGA CONTACT INFO AND PATENTS	2061
42	1	AUS	73x80	DE-000731	KANGA SERVICE AND SPARES	2061
43	2	AUS	130x50	DE-002208	KANGA AUSTRALIAN MADE	2061
44	1		32x56	DE-000880	PARKING BRAKE	
45	1		20x20	DE-000969	BATTERY MASTER SWITCH ON	
46	1		20x20	DE-000970	BATTERY MASTER SWITCH OFF	
47	1		40x20	DE-002067	BATTERY MASTER SWITCH	
48	1		113x130	DE-000849	NAME PLATE KID VHB TAPE	
49	1		110x55	DE-000886	KANGA COMPLIANCE PLATE SERIAL TAG	
50	1		217x65	DE-000839	KID CONTROL PANEL	

NOTES:

The above figures and table show typical safety decal labels location. The actual position and quantity of the labels on your product may differ. Where decals are specific to a region or model, they are highlighted in the region/model column. The remaining decals are common to all models. BEFORE YOU DIG Decal is used in Australia only. Each region should have a similar resource for locating hidden services.

PW220 & PT220 Decal Kits

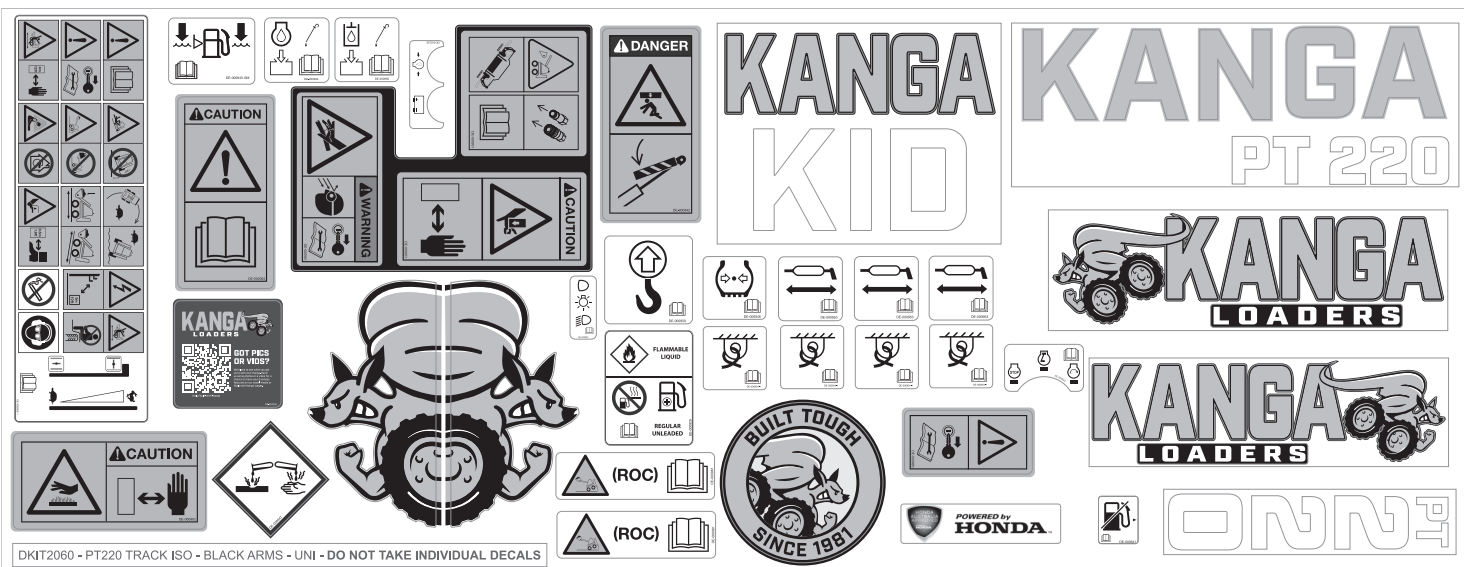
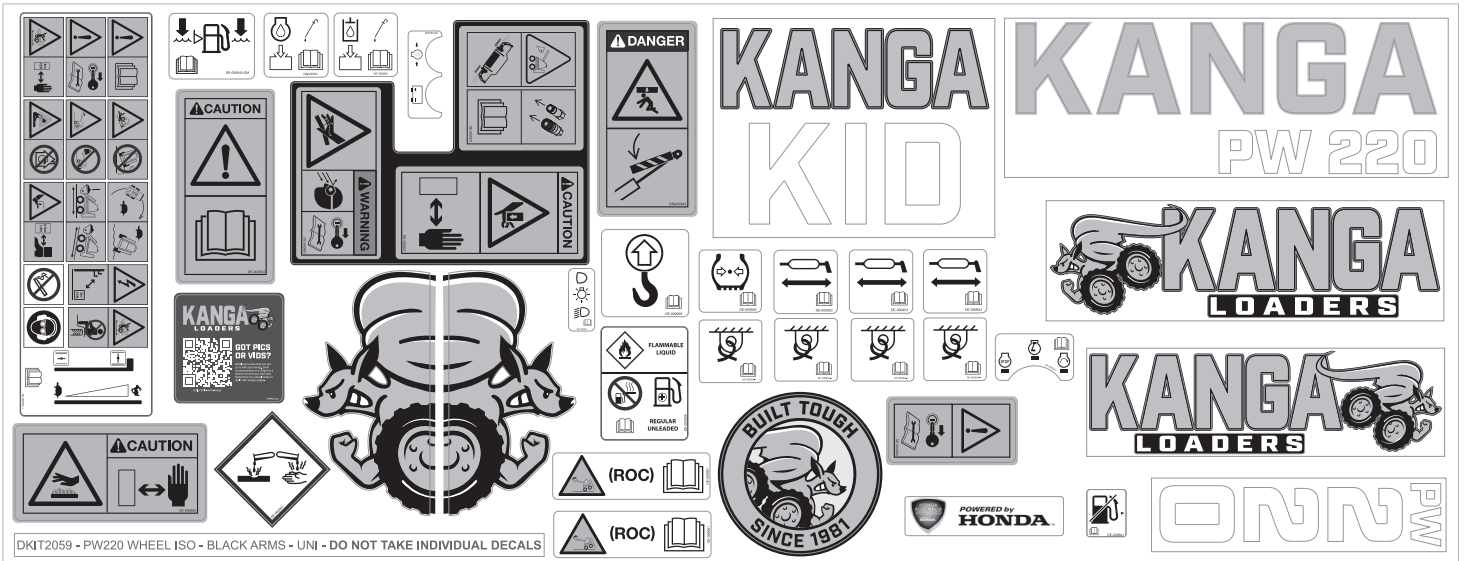

REPLACEMENT PARTS

Description	Part Number
PW220 Decal Kit	DKIT2059
PT220 Decal Kit	DKIT2060

NOTE

Damaged or unreadable safety decals should be replaced. Individual decal part numbers are listed on the previous pages. Contact Kanga Loaders for replacement decals.

Understand Your Warranty

Terms and Conditions

Kanga

5 years - Loader chassis warranty against structural fault.

12 months/or 1000 hours - Warranty for all other loader components.

Honda Engine

36 months - Consumer / Commercial Warranty.

Purchaser's Responsibilities

The purchaser must ensure maintenance and minor adjustments, as detailed in the Operator's Manual and engine manufacturer's manual, are carried out as per the schedule. If there is a discrepancy between the two, the Service Chart in the Operator's Manual will take precedence.

The purchaser must notify Kanga Loaders or an authorized Kanga Loader service representative of the need for warranty repair.

The purchaser must organize and is financially responsible for the transport of the product to and from the place of warranty repair.

Product Registration

The Purchaser must fill out and return the warranty registration card within 30 days of purchase in order to validate the warranty.

Repairs

Call the Kanga dealer in your region for all warranty and repair enquires. For details, phone:

AUSTRALIA & INTERNATIONAL:
Phone: +61 (0)7 3441 9222

NORTH AMERICA:
Phone: +1 833 305 2642

Battery Warranty—Pro Rata

One to three months - Free replacement.

Four to twelve months - Pro rata over 12 months.

Exclusions (No Warranty)

Normal maintenance, servicing, and replacement items such as spark plugs, oil, oil filters, air filter, muffler, tyres, cutting blades and edges, chains, tracks, cables, etc. are not covered by this warranty.

Any equipment which has been altered, misused, incorrectly assembled, improperly adjusted, neglected, or damaged by accident is not covered by this warranty.

Servicing must be completed by a competent organisation in order to maintain the warranty.

Any attachment not approved by Kanga Loader or any parts that are not genuine Kanga Loader service parts are not covered by this warranty.

Engines and engine accessories are covered under the terms of the warranty made by the engine manufacturer, and are not covered by this warranty.

Terms and Conditions (continued)

NOTE

The standard engine manufacturer's warranty is for three (3) years and is subject to their terms and conditions.

Kanga Loaders may from time to time change the design of its products. Nothing contained in this warranty shall be construed as obligating Kanga Loaders to incorporate such changes into previously manufactured products nor shall such changes be construed as an admission that previous designs were defective.

Limitation of Remedy and Damages

The liability of Kanga Loaders under this express warranty, and under any implied warranty that may exist, is limited to repair or replacement of any defective part. In no event shall Kanga Loaders be liable for incidental, special, or consequential damages (including lost profits).

Disclaimer of Further Warranty

Kanga Loaders makes no warranty other than what is expressly made in this warranty. If the law provides that an implied warranty of merchantability, or an implied warranty of fitness for a particular purpose, applies to Kanga Loaders, any such implied warranty is limited to the duration of this express warranty.

Spare Parts Warranty

Terms and Conditions

Kanga Loaders will warrant any part found to be defective within the conditions of normal usage. Breakage or damage to any part caused by abuse or misuse will not be considered. Hydraulic hoses will not be covered by warranty if any signs of external damage are apparent.

Consumables including tyres, tubes, and tracks are not covered by warranty.

The warranty period is for twelve (12) months from the delivery date and applies to only genuine spare parts.

This warranty does not cover any labour, freight, incidental, or consequential charges.

The warranty claim will not be recognized without the return of the faulty part to Kanga Loaders and must include the loader and attachment serial number.

A warranty claim for any engine part is covered by the engine manufacturer's standard warranty contained in the engine manual handbook.

It is the owner's responsibility to ensure that the correct hydraulic and engine oil levels are maintained and that maintenance is carried out as required in the manuals. Claims for damage as a result of insufficient oil levels will not be recognized.

Contact Information

For spare parts, service and support please contact one of our Kanga offices below.

Australia & International

Sales · +61 (0)7 3441 9222

Spare Parts Website · spares.kangaloader.com

Spares Email · info@kangaloader.com

Service Bookings Email · info@kangaloader.com

Visit Our Website · www.kangaloader.com

United States

Sales · +1 833 305 2642

Spare Parts Website · spares.kangaloaderusa.com

Spares Email · infous@kangaloader.com

Service Bookings Email · infous@kangaloader.com

Visit Our Website · www.kangaloaderusa.com

Index

Symbols

4-in-1 39

A

Air Cleaner 59

Air Filter. See Air Cleaner

Angled Blade 44

Arm 52, 77

Attachments 37

Auger 40

B

Backfill Blade. See Angled Blade

Battery 28, 36, 68, 89

Beacon. See Warning Light

Before Starting Up 29

Before You Dig 18

Blade. See Angled Blade

Boom. See Arm

Broom 42

Bucket 39, 42

C

Canister 65

Chain. See Tilt Chain

Charcoal 65

Check 49, 50

Clearance 83

Clearance, Valve 59

Cold 30

Connections, Hydraulic 38

Control 27, 28, 64

Cooler 35

Cooler, Oil 35

Copyright 3

Cowling 57

D

Daily Checklist 50

Dash 28

Decal 9, 84, 86, 88

Delivery 23

Dimensions. See Schematic

Dipstick 59, 60

Disclaimer 3

Disposal 55

Drain, Oil 63

Drive System 78

E

Electric 73

Emergency Stop 36

Emissions 65

End-of-Service-Life 55

Engine 58, 79

EVAP. See Canister

F

Filter. See Air Cleaner; See also Oil Filter; See also Hydraulics

Fork 44

Framing 3

Fuel 34, 83

Fuel Filter 59

Fuse 73

G

Gasoline. See Fuel

Gauge. See Pressure Gauge

Grease 66

H

Headlight 35

Height 83

Hoe 43

Honda 89

Hour-meter 28, 56

Hydraulic, Auxiliary 79

Hydraulic Connections 38

Hydraulic Filter 60

Hydraulic Fitting 38

Hydraulic Pump 78

Hydraulics 60

I

Idle 59

Ignition 28

Inspection 23, 49, 72

Intervals, Service 74, 77

ISO 63

Isolator, Battery 36

J

Jack. See Track Tool

L

Labels. See Decal

Lashing 25, 26

Led 35. See also Warning Light
 Length 83
 Levers 27
 Lifting 26
 Lift Pressure 62
 Loading 24, 25

M
 Maintenance 49
 Manoeuvring 31
 Model 7

N
 Nipples, Grease. See Grease

O
 Oil 28, 58
 Oil Filter 59
 Operate 23
 Overcenter Valve 62

P
 Panel, Instrument. See Dash
 Parking Brake 33, 67
 Patent 3
 Personal Protective Equipment 19
 Petrol. See Fuel
 Pictograms 12. See also Decal
 Pins. See Pivot Pins
 Pivot Pins 69
 Plate. See Product Plate
 Power 83
 Power Head 40
 PPE. See Personal Protective Equipment
 Pressure 62, 83
 Pressure Filter 60
 Pressure Gauge 62
 Pressure, Tyres 71
 Product Plate 7
 Product Registration 89
 Proprietary Statement 3
 Protection Bars 35
 Pump 83

Q
 QRC. See Hydraulic Connections
 Quick Release Couplings. See Hydraulic Connections

R
 Rated Operating Capacity 16, 83
 Recycle 55
 Refuelling 34
 Relief Pressure 62
 Reverse Beeper 35
 Risk Assessment 20
 ROC. See Rated Operating Capacity

Rotary Hoe 43

S
 Safety 2, 13, 25
 Schedule. See Intervals, Service
 Schematic 80, 82
 Scissor Jack. See Track Tool
 Service 56
 Settings, Pressure 62
 Shutting Down 32
 Slope 14
 Spare Parts 91
 Spark Plugs 59
 Specifications 80, 83
 Start 28, 30
 Storage 53, 54
 Switch 28
 Switch, Headlight 28. See also Headlight
 Symbol. See Pictograms

T
 Table of Contents 4
 Terms and Conditions 89
 Test Point 62
 Tilt Chain 70
 Tipping Load 16, 83
 Track 45, 47
 Track Tool 46
 Trade marks 3
 Trencher 41
 Troubleshooting 77
 Turning 31
 Tyne 44
 Tyres 71

U
 Unloading 24
 URO Track 47

V
 Valve 59. See also Overcenter Valve
 Vapour 65
 Viscosity 63. See also Oil

W
 Warning Light 28, 35
 Warranty 89
 Width 83
 Working Hours. See Hour-meter



PM-000249-B

V11.0