



# OPERATOR'S MANUAL



## Extreme Brush Cutter

### MODEL NUMBERS:

1BCSF60	60" Skid Steer Standard Flow
1BCSF60T	60" Skid Steer Standard Flow w/ Teeth
1BC72SF72	72" Skid Steer Standard Flow
1BC72SF72T	72" Skid Steer Standard Flow w/ Teeth
1BCMF60	60" Skid Steer Mid Flow
1BCMF60T	60" Skid Steer Mid Flow w/ Teeth
1BCMF72	72" Skid Steer Mid Flow
1BCMF72T	72" Skid Steer Mid Flow w/ Teeth
1BCHF72	72" Skid Steer High Flow
1BCHF72T	72" Skid Steer High Flow w/ Teeth

## READ ENTIRE OPERATOR'S & PARTS MANUAL BEFORE OPERATING!

DANGER!



ROTATING BLADE HAZARD! STAY BACK!

OBJECTS CAN BE THROWN!

DO NOT operate near bystanders.

DO NOT place hands or feet under deck while in operation or with engine running.



DO NOT operate without a shatterproof door (or front shield) installed on the vehicle.



WARNING! Before leaving the operator's seat: Lower the lift arms against frame and place unit on skid shoes. Disengage auxiliary hydraulics. Stop Engine. Engage parking brake. Remove key.

DANGER!



FLYING DEBRIS HAZARD. CLEAR AREA OF BYSTANDERS AND LIVESTOCK BEFORE OPERATING. THE BRUSH CUTTER IS CAPABLE OF PRODUCING LARGE AMOUNTS OF FLYING DEBRIS IN ALL DIRECTIONS.



WARNING! Lift Limiting chains must be properly installed before operation.



UtiliTough brush cutters should never be operated with the back of the unit more than 12" (305 mm) above the ground.

If there is any portion of this manual or function you do not understand, contact UtiliTough, Inc.

Congratulations on the purchase of your new UtiliTough Extreme Brush Cutter. This product was carefully designed and manufactured to give you many years of dependable service. Only minor maintenance (such as cleaning and lubricating) is required to keep it in top working condition. Be sure to observe all maintenance procedures and safety precautions in this manual and on any safety decals located on the brush cutter and on any equipment on which the attachment is mounted.

**This manual has been designed to help you do a better, safer job. Read this manual carefully and become familiar with its contents.**



**WARNING!** Never let anyone operate this unit without reading the "Safety Precautions" and "Operating Instructions" sections of this manual. Always choose hard, level ground to park the vehicle on and set the brake so the unit cannot roll.

Unless noted otherwise, right and left sides are determined from the operator's control position when facing the attachment.

**NOTE:** The illustrations and data used in this manual were current (according to the information available to us) at the time of printing, however, we reserve the right to redesign and change the brush cutter as may be necessary without notification.

## **BEFORE OPERATION**

The primary responsibility for safety with this equipment falls to the operator. Make sure the equipment is operated only by trained individuals that have read and understand this manual. If there is any portion of this manual or function you do not understand, contact your local authorized dealer or the manufacturer to obtain further assistance. Keep this manual available for reference. Provide the manual to any new owners and/or operators.

## **SAFETY ALERT SYMBOL**



This is the "Safety Alert Symbol" used by this industry. This symbol is used to warn of possible injury. Be sure to read all warnings carefully. They are included for your safety and for the safety of others working with you.

## **SERVICE**

Use only replacement parts from UtiliTough. Substitute parts may not meet the required standards.

Record the model and serial number of your unit on the cover of this manual. The parts department needs this information to ensure that you receive the correct parts.

# SAFETY STATEMENTS



THIS SYMBOL BY ITSELF OR WITH A WARNING WORD THROUGHOUT THIS MANUAL IS USED TO CALL YOUR ATTENTION TO INSTRUCTIONS INVOLVING YOUR PERSONAL SAFETY OR THE SAFETY OF OTHERS. FAILURE TO FOLLOW THESE INSTRUCTIONS CAN RESULT IN INJURY OR DEATH.



## **DANGER**

THIS SIGNAL WORD IS USED WHERE SERIOUS INJURY OR DEATH WILL RESULT IF THE INSTRUCTIONS ARE NOT FOLLOWED PROPERLY.



## **WARNING**

THIS SIGNAL WORD IS USED WHERE SERIOUS INJURY OR DEATH COULD RESULT IF THE INSTRUCTIONS ARE NOT FOLLOWED PROPERLY.



## **CAUTION**

THIS SIGNAL WORD IS USED WHERE MINOR INJURY COULD RESULT IF THE INSTRUCTIONS ARE NOT FOLLOWED PROPERLY.

## **NOTICE**

NOTICE INDICATES A PROPERTY DAMAGE MESSAGE.

## GENERAL SAFETY PRECAUTIONS

### **WARNING!**

#### **READ MANUAL PRIOR TO INSTALLATION**

Improper installation, operation, or maintenance of this equipment could result in serious injury or death. Operators and maintenance personnel should read this manual, as well as all manuals related to this equipment and the skid steer, loader or tractor thoroughly before beginning installation, operation, or maintenance.



#### **READ AND UNDERSTAND ALL SAFETY STATEMENTS**

Read all safety decals and safety statements in all manuals prior to operating or working on this equipment. Know and obey all OSHA regulations, local laws, and other professional guidelines for your operation. Know and follow good work practices when assembling, maintaining, repairing, mounting, removing, or operating this equipment.



#### **KNOW YOUR EQUIPMENT**

Know your equipment's capabilities, dimensions, and operations before operating. Visually inspect your equipment before you start, and never operate equipment that is not in proper working order with all safety devices intact. Check all hardware to ensure it is tight. Make certain that all locking pins, latches, and connection devices are properly installed and secured. Remove and replace any damaged, fatigued, or excessively worn parts. Make certain all safety decals are in place and are legible. Keep decals clean, and replace them if they become worn or hard to read.



## GENERAL SAFETY PRECAUTIONS

### WARNING!



#### **PROTECT AGAINST FLYING DEBRIS**

Always wear proper safety glasses, goggles, or a face shield when driving pins in or out, or when any operation causes dust, flying debris, or any other hazardous material.

### WARNING!



#### **LOWER OR SUPPORT RAISED EQUIPMENT**

Do not work under raised booms without supporting them. Do not use support material made of concrete blocks, logs, buckets, barrels, or any other material that could suddenly collapse or shift positions. Make sure support material is solid, not decayed, warped, twisted, or tapered. Lower booms to ground level or on blocks. Lower booms and attachments to the ground before leaving the cab or operator's station.

### WARNING!



#### **USE CARE WITH HYDRAULIC FLUID PRESSURE**

Hydraulic fluid under pressure can penetrate the skin and cause serious injury or death. Hydraulic leaks under pressure may not be visible. Before connecting or disconnecting hydraulic hoses, read your prime mover's operator's manual for detailed instructions on connecting and disconnecting hydraulic hoses or fittings.

- Keep unprotected body parts, such as face, eyes, and arms as far away as possible from a suspected leak. Flesh injected with hydraulic fluid may develop gangrene or other permanent disabilities.
- If injured by injected fluid, see a doctor at once. If your doctor is not familiar with this type of injury, ask him to research it immediately to determine proper treatment.
- Wear safety glasses, protective clothing, and use a piece of cardboard or wood when searching for hydraulic leaks. **DO NOT USE YOUR HANDS!**

# GENERAL SAFETY PRECAUTIONS

## DO NOT MODIFY MACHINE OR ATTACHMENTS

**WARNING!**



Modifications may weaken the integrity of the brush cutter and may impair the function, safety, life, and performance of the attachment. When making repairs, use only genuine parts from UtiliTough and following authorized instructions. Other parts may be substandard in fit and quality. Never modify any ROPS (Roll Over Protection Structure) or FOPS (Falling Object Protective Structure) equipment or device. Any modifications must be authorized in writing by UtiliTough.

## SAFELY MAINTAIN AND REPAIR EQUIPMENT

**WARNING!**



- Do not wear loose clothing or any accessories that can catch in moving parts. If you have long hair, cover or secure it so that it does not become entangled in the equipment.
- Work on a level surface in a well-lit area.
- Use properly grounded electrical outlets and tools.
- Use the correct tools for the job at hand. Make sure they are in good condition for the task required.
- Wear the protective equipment specified by the tool manufacturer.

## SAFELY OPERATE EQUIPMENT



Do not operate equipment until you are completely trained by a qualified operator in how to use the controls, know its capabilities, dimensions, and all safety requirements. See your machine's manual for these instructions.

- Keep all step plates, grab bars, pedals, and controls free of dirt, grease, debris, and oil.
- Never allow anyone to be around the equipment when it is operating.
- Do not allow riders on the brush cutter or machine it is connected to.
- Do not operate the equipment from anywhere other than the correct operator's position.
- Never leave equipment unattended with the engine running, or with this attachment in a raised position.
- Do not alter or remove any safety feature from the skid steer, loader, tractor or this brush cutter.
- Know your work site safety rules as well as traffic rules and flow. When in doubt on any safety issue, contact your supervisor or safety coordinator for an explanation.

# BRUSH CUTTER SAFETY PRECAUTIONS

Block off work area from bystanders, livestock, etc. Flying debris can cause severe injury or death. The brush cutter is capable of producing large amounts of flying debris in all directions.

Let others know when and where you will be working. Make sure no one is behind the equipment or for several hundred feet in any direction around the equipment when in operation.

Never allow anyone to approach the brush cutter when in operation.

Do not raise the attachment when the blades are rotating.

Do NOT operate without a shatterproof (demolition) cab door or front shield in-stalled on the loader.

## WARNING!



Operate only from the operator's station.

Do not exceed rated operating capacity of loader. Be sure all covers, front deflector chains and lift limiting chain(s) are properly installed before operating unit.

When mounted onto a skid steer loader, do not operate the brush cutter with the back of the attachment over 12" above the ground.

Do not lift loads in excess of the capacity of the loader. Lifting capacity decreases as the loader is moved further away from the unit.

Never try to board or exit equipment while it is running.

Test all controls before your begin operation.

# EQUIPMENT SAFETY PRECAUTIONS



## OPERATING THE ATTACHMENT

When operating on slopes, drive up and down, not across. Avoid steep hillside operation, which could cause the equipment to overturn.

Reduce speed when driving over rough terrain, on a slope, or turning, to avoid overturning the vehicle.

An operator must not use drugs or alcohol, which can change his or her alertness or coordination. An operator taking prescription or over-the-counter drugs should seek medical advice on whether or not he or she can safely operate equipment. Never leave the attachment unattended when in the raised position. Always make sure both skids are on the ground, parking brake is engaged, engine is turned off and the keys are removed before exiting the vehicle.

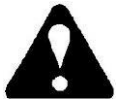

## TRANSPORTING THE ATTACHMENT

Travel only with the attachment in a safe transport position to prevent uncontrolled movement. Drive slowly over rough ground and on slopes.

When transporting on a trailer: Secure attachment using tie down accessories that are capable of maintaining attachment stability.

Use extra care when loading or unloading the brush cutter onto a truck or trailer. Disconnect hydraulic couplers during transporting. When driving on public roads use safety lights, reflectors, Slow Moving Vehicle signs etc., to prevent accidents. Check local government regulations that may affect you. Do not drive close to ditches, excavations, etc., cave in could result.

Do not smoke when refueling the vehicle. Allow room in the fuel tank for expansion. Wipe up any spilled fuel. Secure cap tightly when done.

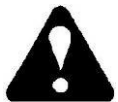

## MAINTAINING THE ATTACHMENT

Before performing maintenance, disengage auxiliary hydraulics, lower the brush cutter to the ground, turn off the engine, remove the key and apply the brakes. Be sure all rotation has stopped before making any adjustments or repairs. Never perform any work on the attachment unless you are authorized and qualified to do so. Always read the operator manual before any repair is made. After completing maintenance or repair, check for correct functioning of the attachment. If not functioning properly, always tag "DO NOT OPERATE" until all problems are corrected.

If attachment must be left raised for maintenance or any other reason, block the unit securely to prevent accidental release of the lifting mechanism. Serious damage or personal injury could result.

Worn, damaged, or illegible safety decals must be replaced. New safety decals can be ordered from UtiliTough.

Never make hydraulic repairs while the system is under pressure. Serious personal injury or death could result.

Never work under a raised attachment.

# PREOPERATION

## GENERAL INFORMATION

The UtiliTough brush cutter is operated by the skid steer or other vehicle's auxiliary hydraulics and mounts to the "Universal Quick Attach" hook-up for easy operator access. Your skid steer loader must have an auxiliary hydraulic system and a shatterproof door or front shield to operate this brush cutter.

**DANGER!**



**TO AVOID SERIOUS PERSONAL INJURY OR DEATH THE UTILITOUGH BRUSH CUTTER MUST NOT BE ATTACHED TO ANY POWER UNIT THAT DOES NOT HAVE A SHATTERPROOF DOOR (OR FRONT SHIELD) INSTALLED.**

# INSTALLATION INSTRUCTIONS

## GENERAL INFORMATION

The following instructions will help you to mount your brush cutter onto your skid steer loader. The brush cutter uses the quick-attach system for ease of installation. Therefore, if you know how to attach your loader bucket, attaching the brush cutter should prove no problem.

Remember to read all safety warnings, decals and operating instructions before operating the attachment. If there is any portion of this manual that you do not understand, contact your dealer.

### **DANGER!**



**TO AVOID SERIOUS PERSONAL INJURY OR DEATH THE UTILITOUGH BRUSH CUTTER MUST NOT BE ATTACHED TO ANY POWER UNIT THAT DOES NOT HAVE A SHATTERPROOF DOOR (OR FRONT SHIELD) INSTALLED.**

## ATTACHING TO SKID STEER / LOADER

**NOTE: Before attaching the brush cutter to your loader, make sure a shatterproof door (or front shield) has been installed onto the front of your skid steer loader.**

1. Remove any attachments from the front of the loader.
2. Following all standard safety practices and the instructions for installing an attachment in your skid steer operator's manual, install the brush cutter onto your skid steer loader.

**NOTE: It is important to make sure the locking mechanism on your quick attach is engaged, therefore locking the attachment onto the skid steer.**

3. Connect the Lift Limiting Chain to the front of your skid steer loader. The back of the brush cutter should never be more than 1 foot off the ground for proper and safe cutting. (Raise the unit to 1-foot above ground level. Route the end of the Lift Limiting Chain from the back of the brush cutter and then through the tie down mechanism(s) on the front of your skid steer loader. Tie the chain securely back to itself with the shackle provided, to limit the lifting capabilities of the cutter to 1 foot maximum.)
4. Lower the unit to the ground and remove the key.
5. After making sure that there is not any foreign matter on the hydraulic couplers, connect the couplers to the auxiliary hydraulic system of your skid steer loader.

## DETACHING FROM SKID STEER / LOADER

1. On firm, level ground, lower the attachment so both skids are on the ground, parking brake is engaged, engine is turned off and the keys are removed.
2. Follow your skid steer loader operator's manual to relieve pressure in the hydraulic lines.
3. Disconnect couplers and either connect them together or install dust caps and plugs to prevent contaminants from entering the hydraulic system. Store hoses on attachment, off the ground.
4. Follow your skid steer loader operator's manual for detaching (removing) an attachment.

# OPERATING INSTRUCTIONS

**INTENDED USE:** The UtiliTough Extreme Brush Cutter is designed for cutting brush and small trees up to 7" (178mm) in diameter while still maintaining a 12" (305mm) maximum ground clearance.

When equipped with the optional "Chipper Tooth" kit it will grind stumps down to 1.25" from ground level. Use in any other way is considered contrary to its intended use.

## GENERAL INFORMATION

The brush cutter attaches to the "Universal Quick Attach" skid steer loader. Due to this arrangement, thorough knowledge of the skid-steer controls is necessary for machine operation. Read and understand your skid steer operator's manual for information regarding skid steer operation before attempting to use the brush cutter.

Follow all installation instructions for the proper installation of the unit onto your skid steer before attempting to operate your brush cutter.

## OPERATING TIPS

Continuous rotation of the blades is required during operation to prevent overheating of the hydraulic system. If the brush cutter stalls, disengage auxiliary hydraulics, and remove cutter from debris before restarting.

**WARNING! Before leaving the operator's seat: Lower the lift arms against frame and place both skid shoes on the ground. Disengage auxiliary hydraulics. Stop Engine. Engage parking brake. Remove the key.**

**DANGER!**



**ROTATING BLADE HAZARD! STAY BACK!**

**OBJECTS CAN BE THROWN!**

**DO NOT** operate near bystanders.

**DO NOT** place hands or feet under deck while in operation or with engine running.

**DO NOT** operate without a shatterproof door (or front shield) installed on loader.

**WARNING!** Lift limiting chain must be properly installed before operation.

# OPERATING INSTRUCTIONS

## CUTTING OPERATION

1. Raise the back of the unit off of the ground approximately 4" to allow the material to clear from under the cutting deck as you travel forward.
2. Place the front skid shoes 2-6" (51-152mm) off the ground. This is the preferred position for cutting grass and heavy vegetation.
  - Never drive your skid steer with the front of the brush cutter tilted to the point your view is obstructed. Always make sure you can see what you are cutting.
  - Check the work area. Never operate the brush cutter in populated areas where thrown objects could injure persons or damage property.
  - Never raise the unit and expose yourself or anyone else to the rotating blades. If you can see the blades then the back of the unit is raised too high. Maximum ground clearance at any time is 12" (305mm).
3. Activate the auxiliary hydraulics with the engine at idle. Increase engine speed.
4. Be sure the brush cutter is operating smoothly and at full speed, and then start forward travel.

## CUTTING LARGE BRUSH AND SMALL TREES UP TO 7" (178mm) IN DIAMETER:

WARNING! Trees can fall in any direction. It is the operator's responsibility to be certain the area is safe and clear of people, animals and personal property.

### When cutting large brush and small trees:

1. Roll the front of the brush cutter up 1-2 feet (305-61 mm). DO NOT LIFT THE BACK OF THE CUTTER!
2. Slowly drive into the tree. The front shield will raise up allowing the push bar on the brush cutter to push against the tree. Due to the angle of the brush cutter this will allow the blades to notch into the tree which will allow the push bar to bend the tree over and finish the cut.
3. If the push bar is unable to bend the tree, back up the skid steer loader and increase the angle of the brush cutter slightly.
4. Repeat Step #2 and #3 until the notch is sufficient (for the size of brush or tree you are cutting) to permit the push over bar to bend the tree.
5. When the cut is complete the remaining tree stump can be cut shorter using the brush cutter blades or it can be easily ground down with the optional tooth kit High-Flow Only.
6. The tree can now be mulched by rotating the front up slightly and driving forward several feet. Repeat, if necessary. Remember do not lift the back of the cutter.

## OPERATING INSTRUCTIONS

### **OPTIONAL TOOTH KIT OPERATION:**

An optional "Chipper Tooth" kit is available on High Flow models. After felling large brush or small trees, position the brush cutter over the stump(s) and using a plunging motion, grind the stump(s) down. To get maximum performance, maintain full speed of the blade carrier when grinding. To achieve this, periodically lift the cutter off of the stump to allow the blade carrier to return to full rpm.

**AVOID STALLING BRUSH CUTTER:** Continuous rotation is required to prevent overheating of the hydraulic system. Overheating of the hydraulic system is caused if hydraulic oil is repeatedly forced over the relief valve setting on either the skid steer or brush cutter (whichever is less).

**TO RESTART BLADE ROTATION:** Disengage auxiliary hydraulics. Remove brush cutter from debris. Engage auxiliary hydraulics to start blade rotation. (Be sure the brush cutter is operating smoothly and at full speed, and then start forward travel again.

**REPEATED STALLING OF ROTATING BLADES:** Disengage auxiliary hydraulics. Remove brush cutter from debris. Review operating conditions and the size/density of material being cut. Make necessary corrections. Engage auxiliary hydraulics to start blade rotation.

## TROUBLESHOOTING OPERATING CONDITIONS:

Below are listed a few operating conditions that may cause repeated stalling of your brush cutter, and suggestions on how to correct them.

**GRASS TOO LONG OR THICK:** If cutting heavy vegetation, you may need to slow travel speed or make smaller passes (less than full cut) to prevent overloading and stalling the unit. Although the brush cutter is not designed for mowing grass, by monitoring blade sharpness and travel speed this can be accomplished.

**BRUSH TOO BIG IN DIAMETER:** The brush cutter is NOT designed to cut trees larger than 7" (178mm) in diameter. If brush is smaller than 7" (178mm) in diameter and the cutter is stalling, check sharpness of the blades (see "Maintenance") and cut using the procedure described earlier in this section for "CUTTING LARGE BRUSH AND SMALL TREES".

**BRUSH TOO THICK OR HEAVY:** If cutting heavy or thick brush, you may need to slow travel speed or make smaller passes (less than full cut), to prevent overloading. If the blades seem to be unable to handle the volume of brush, slow down the travel speed until the unit reaches full speed before proceeding.

**SCALPING THE GROUND or BOTTOMING OUT:** Be aware of changes in the terrain. Stay alert for drop-offs and holes. Check the terrain and the deck position before restarting and continuing cutting.

**STRIKING FOREIGN OBJECTS:** Stay alert for rocks, fencing, abandoned wells, septic tanks or other foreign objects. If the brush cutter comes into contact with a foreign object, stop the unit, shut off the engine and disconnect the hydraulic couplers from the skid steer. Inspect the unit and repair any damage before restarting and continuing cutting. (Never try to weld or straighten damaged blades.) Inspect the work area for any other items, and if they are too large to be removed from the area, they should be flagged clearly.

**NOTE:** When blades are bent or damaged, they will become wedged between the blade carrier plates. This will cause excessive vibration and the blades must be replaced before proceeding (see "Maintenance").

## STORAGE

The following storage procedure will help you to keep your UtiliTough brush cutter in top condition. It will also help you get off to a good start the next time your cutter is needed. We therefore strongly recommend that you take the extra time to follow these procedures whenever your unit will not be used for an extended period of time.

- Clean the unit thoroughly, removing all mud, dirt, and grease.
- Sharpen or replace blades. Replace all blades at the same time and do not try to weld or straighten damaged blades; loss of integrity may result.
- Inspect for visible signs of wear, breakage, or damage. Order any parts required, and make the necessary repairs to avoid delays when starting next season. **NOTE: Purchase only approved replacement parts from UtiliTough.**
- Tighten all loose nuts, cap screws, and hydraulic connections.
- Check the drive bearing housing for proper lubricant level.
- Seal hydraulic system from contaminants and secure all hydraulic hoses off the ground to help prevent damage.
- Replace decals if damaged, or in unreadable condition.
- Apply a rust-preventive spray to all moving parts and to the bottom of the deck.
- Store the unit in a dry and protected place. Leaving the unit outside will materially shorten its life.

## REMOVING FROM STORAGE

- Remove all protective coverings.
- Check hydraulic hoses for deterioration, and replace if necessary.
- Check all nuts and bolts for proper tightness, especially those securing the motor, bearing housing and blades.

# LUBRICATION

## **GENERAL INFORMATION**

Economical and efficient operation of any machine is dependent upon regular and proper lubrication of all moving parts. Neglect leads to reduced efficiency, wear, breakdown, and needless replacement of parts.

The fluid level in the drive bearing housing should be checked each time brush cutter is used. Fill as necessary with hydraulic fluid. Hydraulic fluid maintains its lubrication properties better than gear oil when under high heat and pressure.

# MAINTENANCE

## GENERAL INFORMATION

Regular maintenance is the key to long equipment life and safe operation. Maintenance requirements have been reduced to an absolute minimum. However, it is very important that these maintenance functions be performed as described.



**WARNING! Avoid serious injury. Lower the brush cutter so both skid shoes are on the ground, set the parking brake, stop the skid steer engine, and remove the key before leaving the operator's seat. If unit must be left raised for maintenance, block the unit securely to prevent accidental release of the lifting mechanism. Disconnect the hydraulic couplers.**

PROCEDURE	DAILY	AT 40 HOURS	1200 HOURS
Check skid steer loader hydraulic system fluid level.	✓		
Check mounting hardware on blades and tighten if necessary. See Bolt Torque Specifications.	✓		
Check all other hardware and tighten if necessary. See Bolt Torque Specifications.	✓		
Check hydraulic system for fluid leaks.	✓		
Check blades for damage and sharpen or replace as needed.	✓		
Check for missing or illegible Safety and Warning decals.	✓		
Check fluid level in drive bearing housing and add if necessary.		✓	
Change hydraulic fluid in drive bearing housing.			✓

**Escaping fluid under pressure can have sufficient force to penetrate the skin-causing serious personal injury. Fluid escaping from a very small hole can be almost invisible. Use a piece of cardboard or wood, rather than hands to search for suspected leaks.**



**Keep unprotected body parts, such as face, eyes, and arms as far away as possible from a suspected leak. Flesh injected with hydraulic fluid may develop gangrene or other permanent disabilities.**

**If injured by injected fluid, see a doctor at once. If your doctor is not familiar with this type of injury, ask him to research it immediately to determine proper treatment.**

## MAINTENANCE

**WARNING!**  Avoid serious injury. Lower the brush cutter so both skid shoes are on the ground, set the parking brake, stop the skid steer engine, and remove the key before leaving the operator's seat. Be sure all rotation has stopped before making any adjustments or repairs. If unit must be left raised for maintenance, block the unit securely to prevent accidental release of the lifting mechanism. Disconnect the hydraulic couplers.

### REPLACING BLADES

When replacing or sharpening the blades, the unit does not require blocking. Place unit firmly on the ground and disconnect the hydraulic couplers.

The blades should be inspected regularly (every 8 hours) to ensure they are sharp, tightened correctly and intact. We recommend replacing all three blades at the same time and NEVER try to weld or straighten damaged blades, as loss of blade integrity may result.

## **REPLACING THE HYDRAULIC MOTOR**

When replacing the hydraulic motor, the unit should be setting firmly on the ground with the hydraulic couplers disconnected. Be sure all rotation has stopped before making any adjustments or repairs.

**NOTE: Replacement of the internal motor seals without prior authorization from factory voids the warranty.**

1. Remove motor cover (four nuts, two on each side of motor housing)

NOTE: Set cover aside taking extra care to not put any strain on the hoses.

2. Remove hoses from the existing hydraulic motor and place in a clean container.

3. Remove the four motor bolts holding the motor to the drive bearing housing, and remove the motor. Motor gasket must be replaced when replacing or servicing the hydraulic motor.

4. Install the new motor with new gasket onto the drive bearing housing using the existing four motor bolts. Bolts should have Loctite® applied before. Torque to specifications. See Bolt Torque Specifications.

5. Re-install motor cover using existing hardware and torque to specification. See Bolt Torque Specifications.

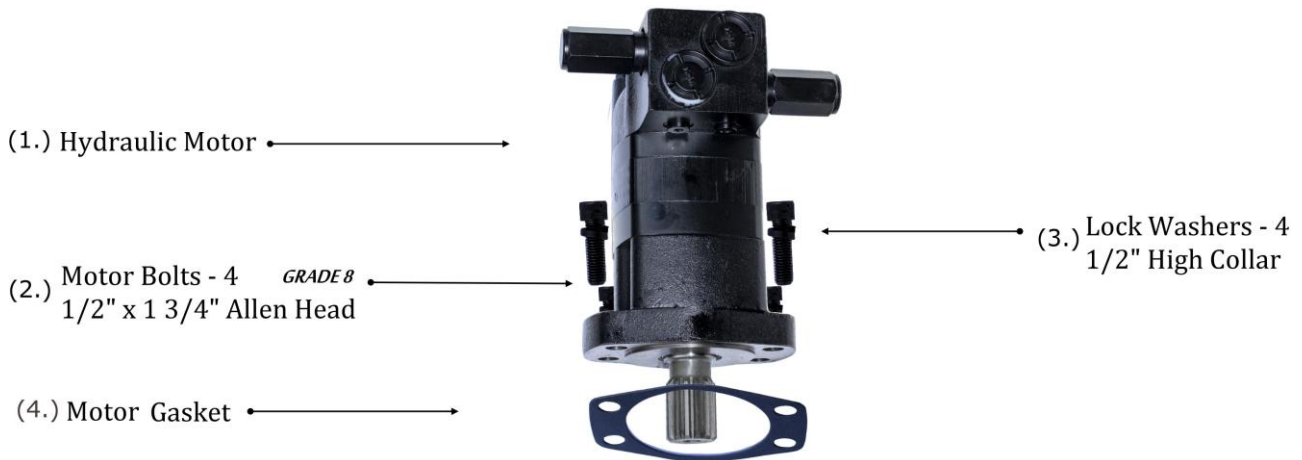
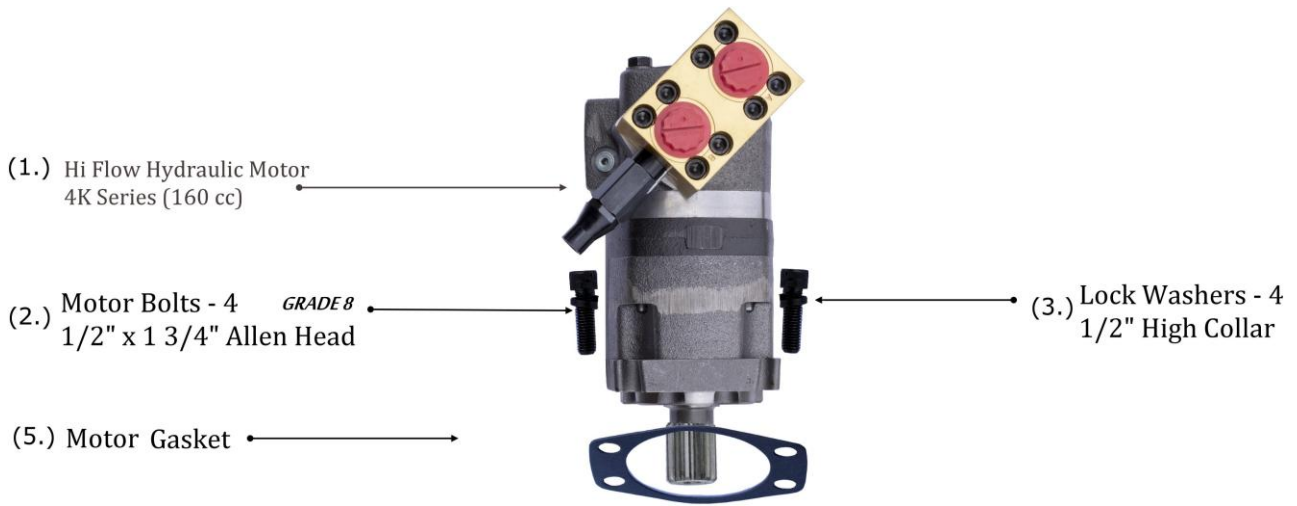

## HUB REPLACEMENT

Contact UtiliTough for hub replacement special instructions or to obtain an RMA.



# BOLT TORQUE SPECIFICATIONS

## GENERAL TORQUE SPECIFICATION TABLES

Use the following charts when determining bolt torque specifications when special torques are not given. Always use grade 5 or better when replacing bolts.



## SAE BOLT TORQUE SPECIFICATIONS

NOTE: The following torque values are for use with extreme pressure lubricants, plating or hard washer applications. Increase torque 15% when using hardware that is un-plated and either dry or lubricated with engine oil.

Bolt Size		SAE GRADE 5 TORQUE				SAE GRADE 8 TORQUE				Bolt head identification marks as per grade. NOTE: Manufacturing Marks Will Vary
		Pounds Feet		Newton-Meters		Pounds Feet		Newton-Meters		
Inches	Millimeters	UNC	UNF	UNC	UNF	UNC	UNF	UNC	UNF	
1/4	6.35	8	9	11	12	10	13	14	18	<p>GRADE 2</p>  <p>GRADE 5</p>  <p>GRADE 8</p> 
5/16	7.94	14	17	19	23	20	25	27	34	
3/8	9.53	30	36	41	49	38	46	52	62	
7/16	11.11	46	54	62	73	60	71	81	96	
1/2	12.70	68	82	92	111	94	112	127	152	
9/16	14.29	94	112	127	152	136	163	184	221	
5/8	15.88	128	153	174	207	187	224	254	304	
3/4	19.05	230	275	312	373	323	395	438	536	
7/8	22.23	340	408	461	553	510	612	691	830	
1	25.40	493	592	668	803	765	918	1037	1245	
1-1/8	25.58	680	748	922	1014	1088	1224	1475	1660	
1-1/4	31.75	952	1054	1291	1429	1547	1700	2097	2305	
1-3/8	34.93	1241	1428	1683	1936	2023	2312	2743	3135	
1-1/2	38.10	1649	1870	2236	2535	2686	3026	3642	4103	

## METRIC BOLT TORQUE SPECIFICATIONS

NOTE: The following torque values are for use with metric hardware that is unplated and either dry or lubricated with engine oil. Reduce torque 15% when using hardware that has extreme pressure lubricants, plating or hard washer applications.

Bolt head identification marks as per grade.		
		

Size of Bolt	Grade No.	Pitch (mm)	Pounds Feet	Newton-Meters	Pitch (mm)	Pounds Feet	Newton-Meters
M6	5.6	1.0	3.6-5.8	4.9-7.9	-	-	-
	8.8		5.8-4	7.9-12.7		-	-
	10.9		7.2-10	9.8-13.6		-	-
M8	5.6	1.25	7.2-14	9.8-19	1.0	12-17	16.3-23
	8.8		17-22	23-29.8		19-27	25.7-36.6
	10.9		20-26	27.1-35.2		22-31	29.8-42
M10	5.6	1.5	20-25	27.1-33.9	1.25	20-29	27.1-39.3
	8.8		34-40	46.1-54.2		35-47	47.4-63.7
	10.9		38-46	51.5-62.3		40-52	54.2-70.5
M12	5.6	1.75	28-34	37.9-46.1	1.25	31-41	42-55.6
	8.8		51-59	69.1-79.9		56-68	75.9-92.1
	10.9		57-66	77.2-89.4		62-75	84-101.6
M14	5.6	2.0	49-56	66.4-75.9	1.5	52-64	70.5-86.7
	8.8		81-93	109.8-126		90-106	122-143.6
	10.9		96-109	130.1-147.7		107-124	145-168
M16	5.6	2.0	67-77	90.8-104.3	1.5	69-83	93.5-112.5
	8.8		116-130	157.2-176.2		120-138	162.6-187
	10.9		129-145	174.8-196.5		140-158	189.7-214.1
M18	5.6	2.0	88-100	119.2-136	1.5	100-117	136-158.5
	8.8		150-168	203.3-227.6		177-199	239.8-269.6
	10.9		175-194	237.1-262.9		202-231	273.7-313
M20	5.6	2.5	108-130	146.3-176.2	1.5	132-150	178.9-203.3
	8.8		186-205	252-277.8		206-242	279.1-327.9
	10.9		213-249	288.6-337.4		246-289	333.3-391.6

# TROUBLESHOOTING

<b>PROBLEM</b>	<b>POSSIBLE CAUSE</b>	<b>POSSIBLE REMEDY</b>
EXCESSIVE VIBRATION	<p>Blades bent</p> <p>Blades damaged or worn</p> <p>Bearing failure (To diagnose bearing failure; rotate blade carrier slowly and listen for bearing noise.</p> <p>Foreign material in blade carrier assembly</p>	<p>Replace bent blades</p> <p>Replace worn blades as a set. Blades need to be of equal weight not to create imbalance.</p> <p>Replace drive bearing housing</p> <p>Remove any foreign material from blade carrier assembly.</p>
CUTTER STALLS EASILY OR LOSS OF POWER	<p>Insufficient hydraulic pressure.</p> <p>Bearing failure: To diagnose bearing failure; rotate blade carrier slowly and listen for bearing noise.</p> <p>Foreign material in blade carrier assembly.</p> <p>Imbalance of blade carrier assembly.</p>	<p>Connect flow meter between brush cutter and skid steer to ensure adequate pressure. (Gallons per minute) (GPM)</p> <p>Replace drive bearing housing.</p> <p>Remove any foreign material from blade carrier assembly.</p> <p>Replace as needed.</p>
STUMP GRINDING STALLS CUTTER OR TAKES EXCESSIVE AMOUNT OF TIME TO COMPLETE	<p>Incorrect operating technique.</p> <p>Damaged or worn chipper teeth.</p> <p>Bearing failure.</p>	<p>See "Optional Chipper Teeth Operating Instructions" for the correct procedure.</p> <p>Replace as needed.</p> <p>Replace drive bearing housing.</p>

## UTILITOUGH LIMITED WARRANTY

### 1 Year Limited Warranty

UtiliTough, a distributor of quality skid steer attachments offers a 1-year limited warranty on all our attachments.

UtiliTough liability for any defect with respect to accepted goods shall be limited to repairing the goods at UtiliTough location or replacing them as UtiliTough shall elect. The above shall be in accordance with UtiliTough adjustment policies. UtiliTough obligation shall terminate twelve (12) months after the delivery of the attachment to original purchaser. This warranty shall not apply to any machine or attachment which shall have been repaired or altered outside UtiliTough. It will be UtiliTough judgment, to affect its stability or reliability, nor which has been misuse, negligence or accident beyond the manufacturer recommended machine rated capacity. If you have any questions in regards to this limited warranty please contact UtiliTough.

### Warranty Claim

To submit a warranty claim, authorization from UtiliTough must be obtained. This warranty does not include freight or delivery charges incurred when returning attachment for servicing. Pickup/delivery charges are the customer's responsibility.

### Exclusions of Warranty

Except as otherwise expressly stated herein, UtiliTough makes no representation or warranty of any kind, expressed or implied, AND MAKES NO WARRANTY OF MERCHANTABILITY IN RESPECT TO IF ATTACHMENTS ARE FIT FOR ANY PARTICULAR PURPOSE. UtiliTough is not liable for any inconvenience, rental or replacement equipment, loss of profits or other commercial loss. Buyer assumes all liability for all personal injury and property resulted from the handling, possession or use of the attachment by the buyer.